



LABCASE

LABORATORY FUME HOOD CATALOG



- **FUME HOODS**
- **SPECIAL HOODS**
- **CANOPY HOODS**
- **FUME REMOVAL**
- **STANDS**
- **ACCESSORIES**

CA Style fume hoods

LABCASE INC.
P.O. BOX 141261 Grand Rapids MI. 49514
616-481-8550
“LABORATORY ENVIRONMENTS”

TABLE OF CONTENTS:

LABCASE INC.

LABORATORY FUME HOODS AND ACCESSORIES

How to order a fume hood.....	1
Fume hood type selection.....	3
Fume hood air profiles.....	4
Fume hood construction specifications	5
Slim Walled fume hoods.....	7
Control Air fume hoods.....	8
Demonstrator fume hoods.....	9
Clean View fume hoods.....	10
Flat Face fume hoods	11
Handicap Accessible fume hoods.....	12
Flat Face Airfoil style fume hoods.....	13
Perchloric fume hoods.....	14
Pass Through fume hoods.....	15
Radio Isotopes fume hoods.....	16
Modular fume hoods.....	17
Single Sided hoods.....	17
Heat Removal & Vision™ hoods.....	18
Interceptor™ fume hoods.....	19
Student Station fume hoods.....	20
Walk-in fume hoods.....	21
Stands and Bases.....	22
Fume / odor Removal systems.....	23
Powder Safety Stations.....	23
Canopy hoods.....	24
Spray Booths / Balance Enclosures.....	25
Mobile Ventilation Station.....	26
Accessories.....	27
Glossary of terms.....	39

FUME HOOD ORDERING INFORMATION:

STEP 1:

- A. Select the model of fume hood that best fills your laboratories needs:
1. Slim Wall, Control Air, Demonstrator, Perchloric Acid, Radio Isotopes, Pass Through, Interceptor, and Flat Face. These hoods are all **bench type hoods** that are mounted on a counter top or base.
 2. All Accessible and HOPEC IV fume hoods: These hoods are designed to meet the needs of the physically challenged. The hood design allows wheel chair access.
 3. Walk-in fume hoods: This hood is designed for large equipment and apparatus.
 4. Special Purpose Hoods: These hoods are more specifically designed to meet your intended use. Consult our engineering design team for help in solving your needs. Distillation & Clean View

STEP 2:

- B. What operating type do you need?
1. For bench type, HOPEC IV, All Accessible, Walk-in and Special Purpose fume hoods there are three classifications:
 - 1) BYPASS (The Low Flow style hood is a Bypass type)
 - 2) ADD AIR SUPPLY
 - 3) RESTRICTED BYPASS

STEP 3:

- C. Select fume hood interior material: (For greater detail see the accessories section)
1. White poly resin, or comparable U.L. approved
 2. Phenolic resin color white or Black epoxy resin
 3. #304 stainless steel or type 316
 4. PVC
 5. Polypropylene

STEP 4:

Select fume hood exterior:

1. Furniture steel powder coated to customers color selection
2. Stainless steel with a number 4 brushed finish
3. Specials – Wood or plastic

STEP 5:

Select a sash configuration: (For greater details see the accessories section)

1. The *standard sash* is a vertical sliding painted or stainless steel frame containing safety glass. All hoods that are 84" and larger contain center mullions.
2. The *Horizontal sliding sash* is constructed from painted steel or stainless steel. The frame houses track top and bottom this allows the trimmed safety glass panels to slide from left to right.
3. The *Combination - horizontal* and vertical sliding sash is constructed from painted steel or stainless steel. But unlike the horizontal sash it can also be opened by sliding it up vertically. All vertically sliding sash are typically counter balanced with a steel weight.

STEP 6:

Select a color: (Use the color chart in the accessories section of this catalog or supplied chart or chips)

STEP 7:

Select the accessories for your fume hood:

For all add on items from alarms to explosion proof lights see the accessories section in this catalog. As a reminder some add on features displayed in the accessories may not be applicable for your fume hood selection. Always consult with your sales representative prior to placing orders to discuss your options.

TESTING:

All fume hood designs are tested in accordance with the American Society of Heating, Refrigerating, and Air Conditioning Engineers (ASHRAE) Test 110-1995. This test is the standard used to evaluate the performance of a fume hood to efficiently capture contaminants. The test consists of three parts which are average face velocity, reverse air flows, and dead air space within the hood along with tracer gas containment. All testing performed on Labcase fume hoods is carried out by an independent HVAC or testing firm for reliable test results.

All fume hoods comply with U.L. 1805 as we are currently certifying our complete product line. We also offer additional certification based on needs per customer request. We are also finishing CSA and CE certification through MET Labs.

QUALITY CONTROL:

Steps have been taken to implement a five step process to eliminate quality defects. This is a continuous improvement program that also eliminates waste and improves the products we sell. For more information on our QC control processes contact Labcase.

REFERENCES: We are a member of ASHRAE for more details see www.ashrae.com

Labcase has used materials for reference to construct product to fall within guidelines pre-established by the Department of Agriculture, Science, and Education & NIH. The subject matter concerned laboratory chemical fume hoods and there relating standards. (For reference see manual 232.1)

"Threshold Limit Values for Chemical Substances and Physical Agents in the Workroom Environment with Intended Changes" is a handbook published by ACGIH.

American Conference of Governmental
Industrial Hygienists, Inc.
P.O. Box 1937
Cincinnati, OH. 45201

For information relating to exposure outside of the fume hood and permissible levels of exposure contact Safety and Health Program Management Branch Administrative Services Division, S&E
Federal BLDG.

6505 Belcrest Road
Hyattsville, Maryland 20782

ARS MANUAL 242.1 (Construction Project Design Standard)

BIOSAFTEY LEVELS:

- A. Bio-safety level 1 (BL1). Involves agents of known or minimal potential hazard to laboratory personnel, animals, and the environment. Presents no potential economic loss to the animal industry.
- B. Bio-safety level 2 (BL2). Involves agents of moderate potential hazard to personnel, animals, and the environment with minimal economic loss to the animal industry.
- C. Bio-safety level 3 (BL3). Involves agents which are indigenous or certain ones that are exotic to the United States which can be contracted via the respiratory route and may cause serious or lethal diseases to man, animals, or cause moderate economic loss to the animal industry.
- D. Bio-safety level 4 (BL4). Involves highly dangerous and exotic agents which pose a high individual risk of life-threatening disease to man and food animals. These agents have the potential for severe economic loss to the animal industries.

Fume hoods and safety cabinets fall into 3 classes based on hazards: (See manual for greater details relating to levels and class.) Those classes are I, II, and III.

WARRANTY:

Labcase warrants the materials and workmanship for a period of one year from time of shipment. This warranty is only good if the products sold have been properly installed. This warranty however will not cover damages incurred during shipping, installation, or the improper use of our products. Labcase Inc. will not be held accountable for any injuries or damages to persons or property caused by misuse or incorrect operation of our products. This applies but is not limited to accidental or intentional circumstances.

An important consideration is the equipment type and its use-

FUME HOOD CLASSES:

Class A Hoods- These hoods are used in when handling extremely toxic and hazardous materials, such as metal carbonyls, carcinogens, beryllium compounds, and tetraethyl lead. The recommended hood face velocity should be 125 to 150 LFM, with minimums of 100 to 125 LFM at any point during operation.

Class B Hoods- This hood is commonly used in most laboratories dealing with materials and operations of the lab. This hood type is designed to protect the operator from noxious fumes and processes generating odors, smoke, fumes, etc.. Recommended face velocity should be 100 LFM. A reduced air consumption fume hood is also a viable choice, see the Low Flow fume hood model for greater detail.

Class C Hoods- Used for materials and conditions where the hazard level is not high. Uses include low toxicity materials like ethanol and strait – chain hydrocarbons to name a couple. Also for materials or operations that generate dust and fumes. Recommended face velocities are 80 LFM with a minimum of 50 LFM during any point of operation.

Ordering information for fume hoods-

Once the class of hood is determined there are a few more criteria to be determined before selecting your fume hood. The hood with all the traits you need should be selected. This could be either a large walk-in type unit to the common Control Air type bench hood to a special purpose unit. This determination is based on your lab or classroom needs.

When looking through the different types of hoods if one particular model does not fully compliment what you are trying to achieve we have an engineering group that will develop a system that works for you. This is really what Labcase has set out to do, develop systems for customers on an individual basis weather it is one hood or 100.

Once you have figured out the type and the specific needs you wish to achieve you must now select an operating type. The selections include **Bypass, Low Air Flow constant volume, Add Air, and Restricted Bypass.**

CONSTANT VOLUME EXHAUST SYSTEMS:

BYPASS - This is the air that is allowed to flow through the fume hood with the sash lowered to keep face velocities within an acceptable level. As the sash is lowered the face velocities rise allowing less air to move through the hood. The bypass helps maintain a clean environment within the hood keeping fumes, smoke, and particles moving into the exhaust. An airfoil of some kind or louvered front panel is typically used to achieve this.

To conserve energy and maintain a constant volume system see the Low Flow style hood in the Fume Hood section. You can greatly reduce the amount of air being pulled from your lab and still maintain a safe working environment. This is our most efficient hood offered

ADD AIR FUME HOODS WITH CONSTANT VOLUME EXHAUST - After consulting with an HVAC expert there maybe a determination that your lab cannot sufficiently supply the fume hood with enough air. In this case an Add Air system is recommended. The air is typically brought in from the outside or another part of the building. This air is dumped in front of the hoods face from above so as the sash opens the added air is taken. This results in higher hood efficiencies and reduced costs to temper your laboratories air. There are some drawbacks to this exhaust system, fore instance controlling the air and its moisture content so as not to interfere with experiments. The Add Air hoods must be balanced once installed.

RESTRICTED BYPASS - Constant volume operation with restricted bypass can be achieved with the help of proper exhaust duct sizing and face opening reducing devices. Use of an airfoil such as with the Labcase Airflow hood or sashes like horizontal and combination can also help. These sash designs can help reduce exhaust volumes as much as 50%. The reduced exhaust volume helps the bypass air volume to be reduced and in doing so still achieve constant volume.

VARIABLE AIR VOLUME (VAV) EXHAUST SYSTEMS:

It is recommended that all VAV systems use restricted bypass fume hoods to maintain the safety and energy savings within the lab. The intent behind the VAV system is to vary the exhaust volume in response to sash position. So as the sash opens up in order to maintain the same face velocity the exhaust volume increases as the sash closes a minimum of air is exhausted. All exhausted air is pulled from the lab/room the system operates in. All sash configurations can be used with this system. This system has its benefits with reduced energy costs but on the down side it is more sophisticated to operate and maintain compared to constant volume.

CONSIDERATIONS FOR FUME HOOD INSTALLATION:

Here are a few things to consider before and after the fume hood is installed. If it is possible when designing a new lab or including a fume hood to an existing one avoid locating the hood next to doors, windows, vents, or main walk ways. The reasoning is to reduce the amount of uncontrolled air near the hood and reduce foot traffic in front of the hood which also causes disturbances in the air. Once the fume hood has been installed take the time to look over all the connections from the exhaust duct, fixture connections, and wiring. If there are problems consult with your contractor to fix the problems related to the install. Once the hood has been looked over, it must then be balanced when it is tied into an exhaust system. Bring in a qualified HVAC expert to balance your hood especially if you will be operating more than one unit on your exhaust system. Verify that the hoods face velocity is where it should be while testing the hood. A smoke test is a good way to see how well the system is functioning. The hood should remove the smoke quickly and proficiently with no drop in air exhaust cfm. Once the items above have been completed you should have years of trouble free service from your new fume hood.

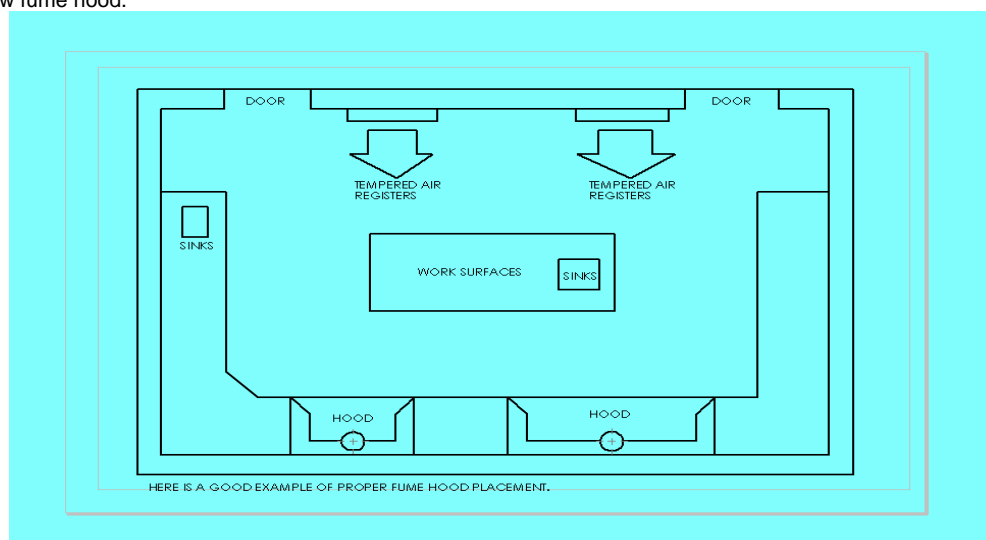

AIR FLOW PROFILES:

The below diagrams represent air patterns based on the type of fume hood from a constant bypass to a restricted bypass.

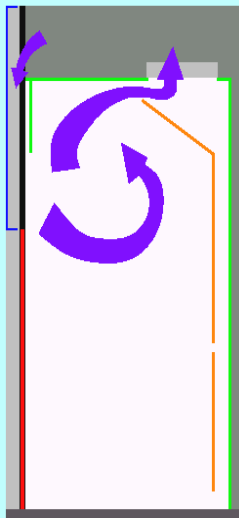

RESTRICTED BYPASS W/ SASH CLOSED

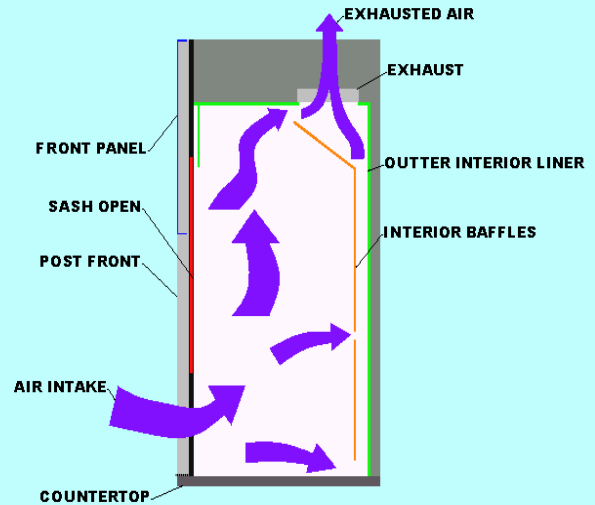

RESTRICTED BYPASS W/ SASH OPEN

The hoods above represent **restricted bypass** hoods', these hoods **do not** have louvers in the front panel or an airfoil. When ordering your fume hoods specify which type you would prefer.

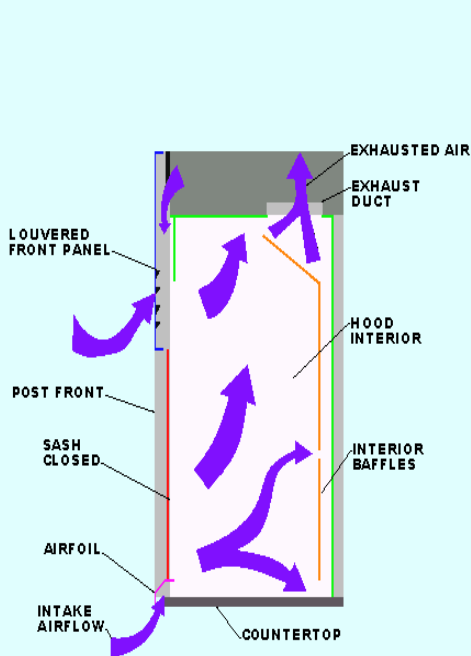

CONSTANT BYPASS W/
SASH CLOSED

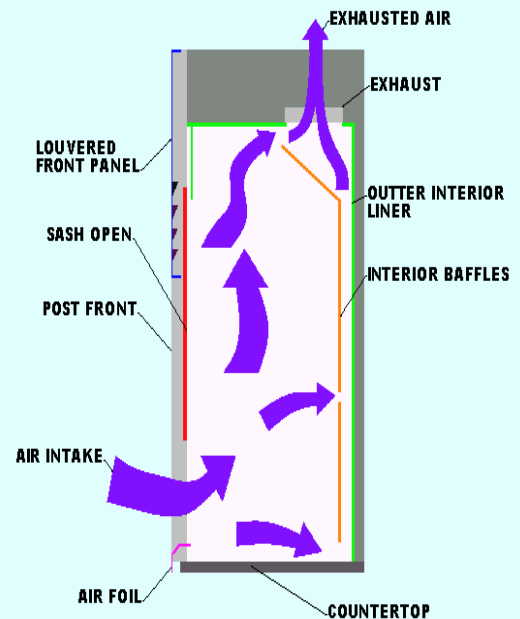

CONSTANT BYPASS W/
SASH OPEN

The above fume hoods represent the **constant bypass** type system with **louvered** front panel and an airfoil. This system allows the air to freely flow through the hood even when the sash is closed. There are many advantages to this type of system the biggest being your fume hood interior will clean out faster if your system is functioning properly. This can be used on all Labcase fume hoods, if you have questions consult with us to answer your questions.

A. STRUCTURAL EXTERNAL:

All external components and materials are fabricated from furniture grade cold rolled steel a minimum of 18 gauge. The steel is then treated in a passivating/ etching bath and washed clean of oils and rust. After the cleaning process the metal is then rinsed off and placed in an oven for drying. After drying is complete the pre-selected chemical resistant finish is applied using modern powder coating processes. After the powder has been applied the parts are then returned to the bake oven for a heat cycle and then left to cool before removal to be assembled.

All fume hoods use a double wall construction feature utilizing a rigid frame construction. The outer and inner components are fastened together to complete the construction. Sash construction is also a minimum of 16 gauge steel either carbon or stainless steel all one piece laser cut and formed for added strength and rigidity. The sash is formed to provide a continuous finger lift across the complete sash assembly. All glass is removable via retainers located on the back side of the sash. All safety glass is ¼" thick dual paned laminated trimmed in a "U" shaped neoprene rubber channel sealed. Note for sash 70" and larger we typically add a center mullion to improve strength. The sash is attached to a counter balance weight located in the back of the hood via a 3/16" thick nylon coated aircraft cable. The cable ride on nylon pulley with a steel ball bearing hub for years of dependable quiet service.

B. STRUCTURAL INTERNAL

The interior lining is manufactured from a white poly resin board from 3/16" to ¼" thick. The liner is manufactured to eliminate screw heads and reduce air flow obstructions. The standard fume hoods also offer gasket sealed access panels on both sides. This allows access into the plumbing and electrical service areas. No special tools or requirements for removing and reinstalling the access panels. Standard wall spacing from the outside to the inside is 5". All interior components are replaceable or removable for cleaning. The baffle system is set with a middle inlet at approximately 18" off the work surface along with upper and lower inlets to improve exhaust patterns. The working height for most models will be a minimum of 48" unless noted.

The material is easily cleaned and resists the growth of bacteria and microbial penetration. The material is also flame resistant and non-heat sensitive. This product is also a U.L. approved product. Special application liners are also offered for more details see accessories section.

C. PRE-WIRE

Some fume hoods require all electrical components be pre-wired prior to delivery. Only certified electricians are allowed to install and wire the electrical components based on applicable national codes. Typically all wiring is routed to a junction box located on top of the fume hood. This includes all light switches, blower switches, simplexes, receptacles, and alarm systems. Only steel conduit is allowed to be used. All wire sizes are based on load requirements. Lighting is designed to provide the maximum amount of light source generated by the respective attached fixture. As per specifications we meet or exceed the 80 foot-candles in the working area. All fixtures are UL rated and approved for there specific application. All final connections made by respective trades.

D. PRE-PLUMB

Some fume hoods require the instillation of plumbing fixtures. All fixtures are installed per national plumbing codes. Piped according to national codes. The customer will designate if the piping will be down, up, or to the back. All piping will terminate within the confines of the fume hood typically 2-3" prior to the outer skin. All final connections made by respective trades.

E. AIRFOIL

Where applicable the airfoil is a directional flow vane mounted to the front of the fume hood at the work surface. It is used to direct air across the work surface even when the sash is closed. It is usually used with By-pass hoods specifically. The airfoil is manufactured from both 304 stainless steel or carbon steel both a minimum of 16 gauge material. The airfoil is powder coated for a chemical resistant finish or if it is stainless steel buffed and polished unless also powder coated per specifications. The airfoil is mounted after the hood is installed per specific trades.

F. ALARMS & LOCKS

All alarms are mounted per manufactures specifications to obtain the best possible readings. This also may include the use of a stop or lock mechanism to maintain optimum operating levels. Sensors are also applied for this application as well with audio and visual alarms to warn users of misuse. All alarms meet ANSI, OSHA, and ASHRAE criteria for safe operation within the laboratory environment. For specific codes and compliance refer to sales representative or the factory.

G. TESTING & APPROVAL

All fume hoods meet ASHRAE 110-1995 testing requirements set forth by ASHRAE. This includes the complete line of Labcase fume hoods. For specific test results please contact your sales representative or the factory. All fume hoods meet the Federal governments OSHA standards for safe operation within the laboratory environment. All fume hoods are constructed to meet U.L. 1805 classification and manufactured from approved materials only.

H. FUME HOODS

All specifications apply to the various types of fume hoods manufactured by Labcase. For the complete list see this catalog or visit our website at www.labcase.com.

I. INSTALLATION

The internal frame structure has pre-punched holes for deck mounting either through the interior access panels or by removing the external side panels. The fume hood is typically mounted to an epoxy resin work surface using stainless steel machine screws or is bolted to the top. All mounting hardware should be stainless steel to increase the life of the install. For seismic conditions a secondary upper and lower bracket system is used to secure the hoods frame to walls or ceiling structures. For more information contact your sales representative or the factory.

FUME HOODS

Rough In Dimensions and Specifications for HVAC and Plumbing connections:

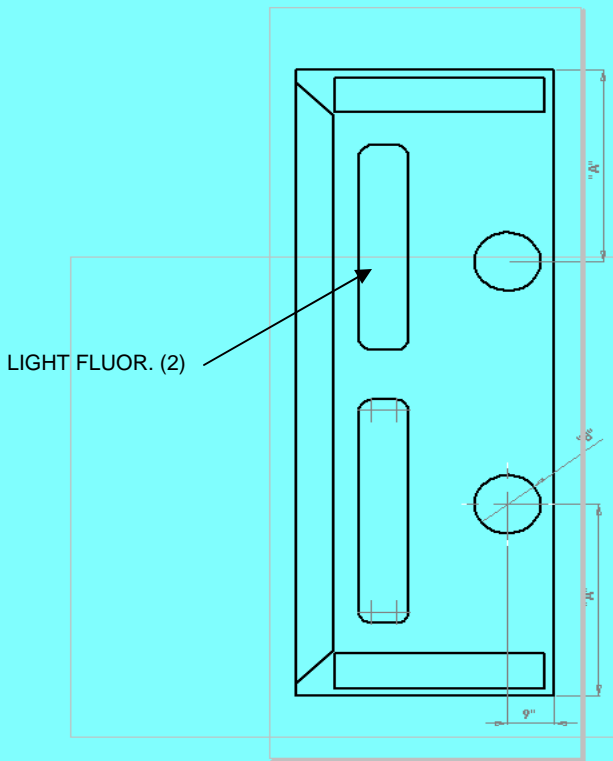

SIZING CHART FOR DIMENSIONS OF EXHAUST DUCTS

- 84" FUME HOOD DIMENSION "A" = 23 1/2" "B" = 9" DIA.
- 94" FUME HOOD DIMENSION "A" = 24" "B" = 10" DIA.
- 96" FUME HOOD DIMENSION "A" = 25" "B" = 10" DIA.

MODELS 84" WIDE AND LARGER

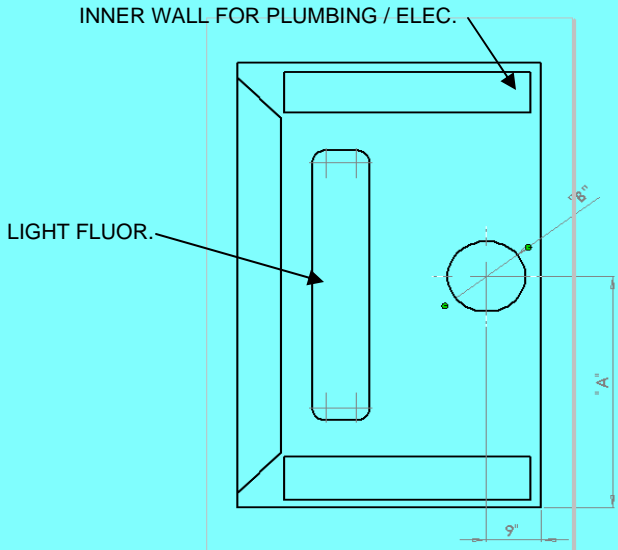

- 35" FUME HOOD DIMENSION "A" = 17 1/2" "B" = 8" DIA.
- 36" FUME HOOD DIMENSION "A" = 18" "B" = 8" DIA.
- 47" FUME HOOD DIMENSION "A" = 23 1/2" "B" = 9" DIA.
- 48" FUME HOOD DIMENSION "A" = 24" "B" = 9" DIA.
- 58" FUME HOOD DIMENSION "A" = 29" "B" = 10" DIA.
- 60" FUME HOOD DIMENSION "A" = 30" "B" = 10" DIA.
- 70" FUME HOOD DIMENSION "A" = 35" "B" = 10" DIA.
- 72" FUME HOOD DIMENSION "A" = 36" "B" = 10" DIA.

MODELS 35" TO 72" WIDE

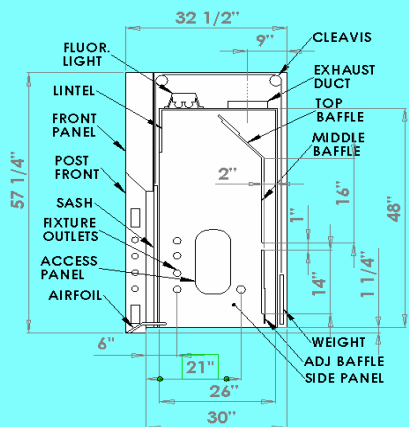

Side Profile for plumbing rough in

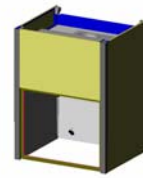

SLIM WALL FUME HOOD:

The slim wall fume hood is designed with simplicity of use and function in mind. The hood utilizes as much space as possible for working area within the hood itself. The interior actually rests against the hoods framework to open up this extra working space. The hoods exterior is constructed of furniture steel and painted with a corrosion resistant finish. The interior is constructed of a white resin for a durable and clean surface. The vertical sliding sash is constructed of furniture steel and painted to match the hood, it encases a 1/4" thick laminated safety glass panel. The vertical sliding sash uses a single counterbalanced weight for smooth and long lasting operation. The design and materials used to construct this fume hood lend themselves for long life and a durable product. This hood is used in both restricted air volume exhaust systems and variable air volume systems. Other options include a louvered front panel for added air bypass, (constant bypass). This fume hood can also use the Add Air System that uses an alternative air source versus taking away tempered air from the lab. The system streams air across the hoods front fascia area and is pulled in through the sash opening or if the sash is closed through the top of the sash. For more details on the Add Air System see the accessories section in this catalog. You can also use stainless steel sash configurations with this hood.

Services-

This hood offers a round duct, two-tube fluorescent light, and painted steel sash. Optional services include an incandescent vapor proof light and square duct. For other options visit the accessories portion of this catalog. Note this hood has very narrow walls that allow little or no access so fixtures including electrical outlets will be mounted off the work surface or through the base cabinet.

SLIM WALL STANDARD FUME HOOD SIZES

** Optional explosion proof blowers*

MODEL NO.	"A" WIDTH	HEIGHT	DEPTH	BLOWER SIZE & MODEL #	CFM	STATIC PRESSURE	EXHAUST DUCT	APPROX. WEIGHT
100-035-SWH	35"	56"	30"	115V. 60Hz 1Ph (1/4 H.P.) 1SW-RTB-035	845	0.28	8" DIA.	151
100-036-SWH	36"	56"	30"	115V. 60Hz 1Ph (1/4 H.P.) 1SW-RTB-036	850	0.30	8" DIA.	155
100-047-SWH	47"	56"	30"	115V. 60Hz 1Ph (1/4 H.P.) 1SW-RTB-047	925	0.25	9" DIA.	176
100-048-SWH	48"	56"	30"	115V. 60Hz 1Ph (1/4 H.P.) 1SW-RTB-048	930	0.27	9" DIA.	181
100-058-SWH	58"	56"	30"	115V. 60Hz 1 Ph (1/2 H.P.) 1SW-RTB-058	1153	0.35	10" DIA.	190
100-060-SWH	60"	56"	30"	115V. 60Hz 1Ph (1/2 H.P.) 1SW-RTB-060	1160	0.40	10" DIA.	210
100-070-SWH	70"	56"	30"	115V. 60Hz 1Ph (1/2 H.P.) 1SW-RTB-070	1408	0.36	10" DIA.	247
100-072-SWH	72"	56"	30"	115V. 60Hz 1Ph (1/2 H.P.) 1SW-RTB-072	1415	0.41	10" DIA.	253
100-094-SWH	94"	56"	30"	115V. 60Hz 1Ph (3/4 H.P.) 1SW-RTB-094	1920	0.43	2 - 10" DIA.	275
100-096-SWH	96"	56"	30"	115V. 60Hz 1Ph (3/4 H.P.) 1SW-RTB-096	1925	0.45	2 - 10" DIA.	280

Typical Applications: General Industry and K thru High School

Added accessory options: Chain and Sprocket driven sash, Explosion proof lights, Switches for blower and lights. Gas fixtures, water fixtures, ceiling enclosures, and work surfaces. Deck mounted plumbing fixtures are offered with standard chrome plated or a chemical resistant finish. Remote controls are typically installed in the supporting casework.

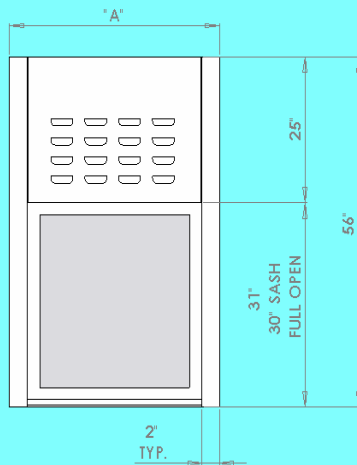

FRONT VIEW

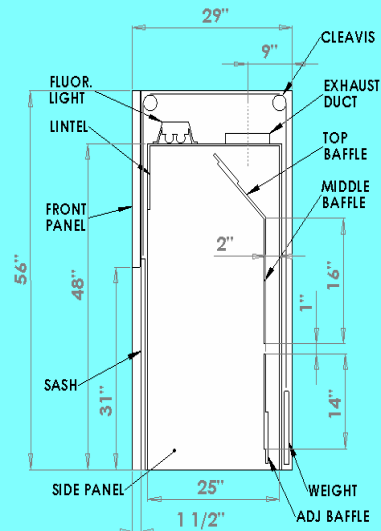

SIDE VIEW

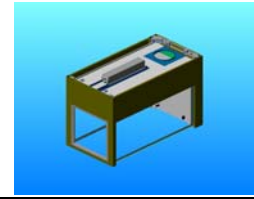

DEMONSTRATOR HOOD:

This hood is designed to allow the operator to demonstrate and still permit the safe viewing via three sides of ¼" thick laminated safety glass. The hood has applications for use in teaching institutions and where ever enlarged viewing is necessary. The hood exterior is constructed of furniture steel and painted with a corrosion resistant finish. The interior is constructed of a white poly resin with adjustable baffles at one end top and bottom. A two tube fluorescent light is standard along with the two painted steel sash and galvanized exhaust duct. This fume hood is used in restricted air volume exhaust systems and variable air volume systems.

Besides the standard louvered front panels there are two other options, one is the non-louvered version of the current front panel. The second is the Add Air System that uses larger fronts with separate intake ducts that allow air from another source to be exhausted through and out of the fume hood. For more information on this unit see the accessories section in this catalog.

Services –

This unit typically does not offer many accessories because there is a lack of wall space within the hood. Options include an incandescent vapor proof light, light switch, blower switch, and electrical receptacles. Deck mounted plumbing fixtures are offered including special chemical resistant finished types.

DEMONSTRATOR STANDARD FUME HOOD SIZES					
MODEL NO.	"A" WIDTH	HEIGHT	DEPTH	EXHAUST DUCT	BLOWER PRT. NO.
100-047-DFH	47"	48"	31"	10" DIAMETER	1DM-RTB-047
100-048-DFH	48"	48"	31"	10" DIAMETER	1DM-RTB-048
100-059-DFH	59"	48"	31"	10" DIAMETER	1DM-RTB-059
100-060-DFH	60"	48"	31"	10" DIAMETER	1DM-RTB-060

Blowers are single or three phase with optional explosion proof option

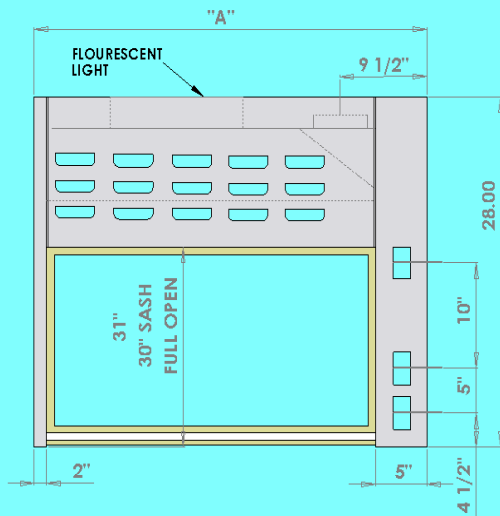

FRONT VIEW

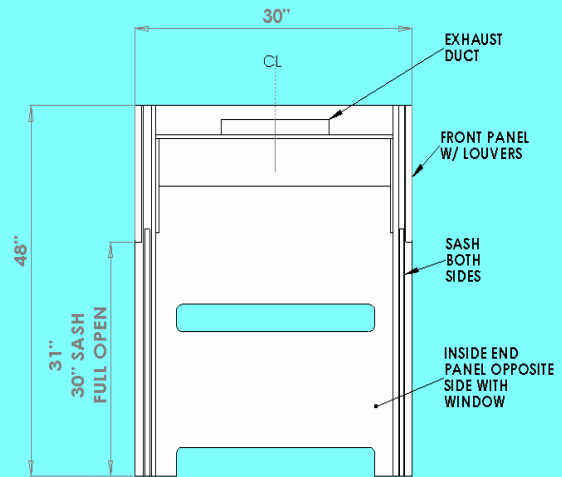

SECTION VIEW

This fume hood has been designed for the educational market where viewing from multiple sides aids in demonstrating or teaching students. The two larger end posts can accommodate electrical outlets along with blower and light switches. The hoods counterweight configuration does not permit plumbing in the walls.

The Demonstrators end window is trimmed out in polished stainless steel.

The hood can also be designed to incorporate a sash lock for security reasons when the hood is not in use. For more details on this fume hood contact Labcase for your answers.

Applications: K thru university

Added Accessory Options: Sash position sensor with alarm, sash locks, sash stops, sash material options, and electrical options. Deck mounted plumbing fixtures are offered with standard chrome plated or a chemical resistant finish. Remote controls are typically installed in the supporting casework. Work surface options as well from epoxy resin to phenolic.

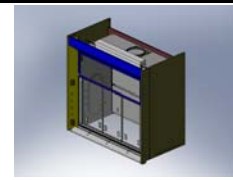

CLEAN VIEW STYLE HOODS:

The CVH is design to allow users full view of the interior working space. The combination sash and upper tempered / tinted glass viewing window give the user a clean sight line from top to bottom. You can use either a combination type sash or a standard sash configuration. There is also the added option for full access into the working space when required by a spring pin front glass panel removal system. This allows you to gain complete access after the sash is pushed up past the shortened front panel.

Another version of this system utilizes clear partial side walls to allow viewing from the sides as well. This works well in areas that allow side access such as islands. These can be put back to back or side to side with pass through as needed. This system uses the same construction as the CA style hood with an inner frame and outer sheet metal skin.

Services-

The CVH style hood comes standard with a T-8 two tube fluorescent light and round ducts along with alarm. Optional services include an incandescent vapor proof light, light switch, blower switch, air, gas, vacuum, water, electrical receptacles, and square duct when specified. Fixture configurations are optional based on customer needs. The post fronts are pierced based on the customers request otherwise there will be no cutouts. The hood liner is also pierced in pre-identified locations based on request otherwise the liner will not have holes. For more options and to add items to this style hood look in the accessories section of this catalog.

CLEAN VIEW STANDARD FUME HOOD SIZES					
MODEL NO.	"A" WIDTH	HEIGHT	DEPTH	EXHAUST DUCT	BLOWER PRT. NO.
100-047-CVH	47"	60"	32 3/4"	10" DIAMETER	1LF-RTB-047
100-048-CVH	48"	60"	32 3/4"	10" DIAMETER	1LF-RTB-048
100-058-CVH	58"	60"	32 3/4"	10" DIAMETER	1LF-RTB-058
100-060-CVH	60"	60"	32 3/4"	10" DIAMETER	1LF-RTB-060
100-070-CVH	70"	60"	32 3/4"	12" DIAMETER	1LF-RTB-070
100-072-CVH	72"	60"	32 3/4"	12" DIAMETER	1LF-RTB-072
100-094-CVH	94"	60"	32 3/4"	10" DIAMETER 2	1LF-RTB-094
100-096-CVH	96"	60"	32 3/4"	10" DIAMETER 2	1LF-RTB-096

Note: Blowers are offered in single or three phase and optional explosion proof.

Applications: K thru High School, University, Industrial, Special applications, and Institutional

Added Accessory Options: Electrical fixtures, pre-wire, pre-plumb, sash materials, explosion proof fixtures, chemical resistant coated plumbing fixtures, chain and sprocket sash, work surfaces, alarms, sash stops, sash locks, sash sensor with alarm, ceiling enclosures, and explosion proof lighting.

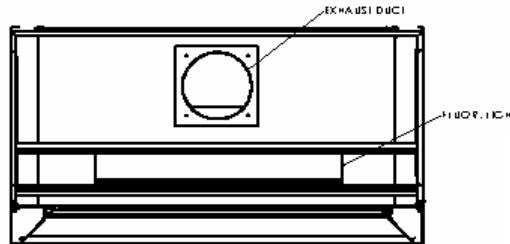

Not shown but offered:

This same unit is also offered in a 180- series. This series has side windows running top to bottom that almost matches the sash opening including upper viewing window. This allows visual access from three sides. Put two systems back to back or side by side with pass through options as well. This unit offers an instructor a clean and safe fume hood to educate students. This is also helpful for general users to keep an eye on there experiments from a vantage point other then in front of the hood. For more detail contact your dealer or representative for further details and pricing.

Note even with the side windows plumbing and electrical services can be accommodated with this fume hood design.

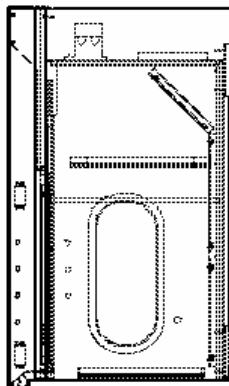

SIDE VIEW

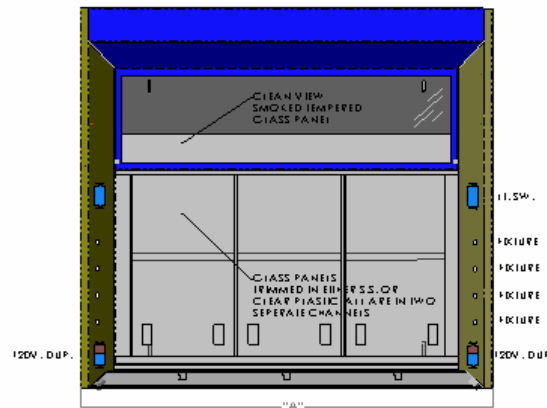

FRONT VIEW

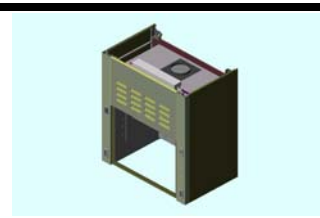
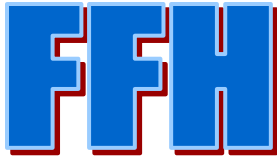

FLAT FACE FUME HOOD:

The flat face style fume hood is of a double wall construction, allowing for the installation of service outlets on both sides of the hood. All the controls can be mounted on the hoods post fronts allowing for easy manipulation. The hood comes with inner and outer access panels to allow servicing of valves and electrical connections. The hood exterior is constructed of furniture steel and painted with a corrosion resistant finish.

The interior is constructed of a chemical resistant white poly resin or phenolic resin that is both durable and easy to maintain.

The hoods sash is constructed of furniture steel and painted to match hood. The vertical sliding sash encases a 1/4" thick panel of laminated safety glass and uses a counterbalance weight for smooth operation. For more sash options turn to the accessories section in this catalog.

This hood has louvers in the front panel for constant bypass. The hood can use the Add Air System for greater energy savings for more details about this system see the accessories section in this catalog.

Services-

This hood comes standard with a two tube fluorescent light and a round exhaust duct. Optional services include light switch, blower switch, air, gas, vacuum, water, electrical receptacles, vapor proof incandescent light, and square duct. All items available along with a full selection of additional items in the accessories section in this catalog. All fume hood front posts are pierced for fixtures based on customer specifications. The hood interior liner will only have holes where fixtures are requested by customer. This hood can be used with restricted air volume exhaust systems and variable air volume exhaust systems based on customers needs, louvers in the front are based on need.

FLAT FACE STANDARD FUME HOOD SIZES

*Note - call for optional explosion proof blowers

MODEL NO.	"A" WIDTH	HEIGHT	DEPTH	Blower Size & Model #	CFM	SP	EXHAUST DIAMETER	LBS WEIGHT
100-035-FFH	35"	56"	30"	115V. 60Hz 1Ph (1/4 H.P.) 1FF-RTB-035	752	0.37	8"	185
100-036-FFH	36"	56"	30"	115V. 60Hz 1Ph (1/4 H.P.) 1FF-RTB-036	759	0.39	8"	189
100-047-FFH	47"	56"	30"	115V. 60Hz 1Ph (1/4 H.P.) 1FF-RTB-047	831	0.38	9"	199
100-048-FFH	48"	56"	30"	115V. 60Hz 1Ph (1/4 H.P.) 1FF-RTB-048	835	0.36	9"	205
100-058-FFH	58"	56"	30"	115V. 60Hz 1 Ph (1/2 H.P.) 1FF-RTB-058	1086	0.34	10"	224
100-060-FFH	60"	56"	30"	115V. 60Hz 1Ph (1/2 H.P.) 1FF-RTB-060	1099	0.46	10"	228
100-070-FFH	70"	56"	30"	115V. 60Hz 1Ph (1/2 H.P.) 1FF-RTB-070	1359	0.44	10"	270
100-072-FFH	72"	56"	30"	115V. 60Hz 1Ph (1/2 H.P.) 1FF-RTB-072	1366	0.45	10"	276
100-094-FFH	94"	56"	30"	115V. 60Hz 1Ph (3/4 H.P.) 1FF-RTB-094	1878	0.5	2- 10"	301
100-096-FFH	96"	56"	30"	115V. 60Hz 1Ph (3/4 H.P.) 1FF-RTB-096	1884	0.5	2- 10"	311

Applications: Industrial, University, & K thru High School

Added Accessory options: Chain and sprocket sash, explosion proof lights and electrical fixtures, special chemical resistant coated plumbing fixtures, alarms, sash sensor w/ alarm, ceiling enclosures, pre-wire, pre-plumb, work surfaces. Remote baffle, sash configurations and material choice, and sash stops.

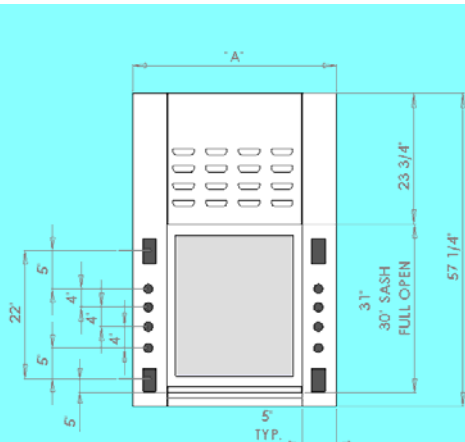

FRONT VIEW

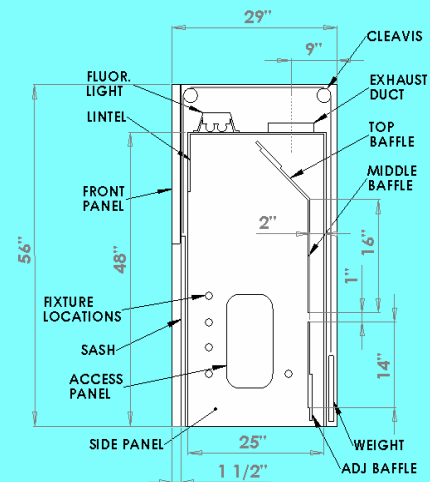

SIDE SECTION VIEW

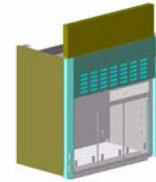

HANDICAP ACCESSIBLE FUME HOODS:

This hood is specifically designed to meet the needs of a sitting or standing individual to operate the controls. The bottom storage cabinet easily moves out of the way for wheelchair access. Once the hood is no longer being used simply roll the cabinet back in place. Another feature is the combination trough airfoil which is designed to capture spills and is removable.

The hood is constructed of furniture steel and painted with a corrosion resistant finish. This hood also utilizes components manufactured from stainless steel. The HAH hood uses a combination horizontal and vertical sliding sash with a viewing window across the top. The sash is constructed of stainless steel and uses a lock that keeps it in the fully closed position and at a second location 18" above the work surface. The sash uses a single counterbalanced weight for smooth and reliable operation. The individual 1/4" laminated safety glass panels are trimmed with a stainless steel molding and slide in two individual guides top and bottom within the sash frame. The top-viewing window runs the entire length of the sash and is clear lexan plexi glass.

The post front panels have removable panels for access to piping and electrical wiring running within the hoods walls. The hoods double wall construction allows for plumbing and electrical installations. This fume hood has a unique feature the airfoil is combined with a trough in the front of the work surface to catch spills. The trough is constructed from stainless steel and uses a drain at one end (optional). The interior baffle openings in the middle and bottom are covered with screens to keep papers from being sucked up. The hood comes with a 2-tube fluorescent light, light switch, one duplex, enclosed sash cap, and round stainless steel duct. A dished 1 1/4" thick black epoxy resin countertop and 3"X6" flush mounted cup sink. Options include a steel ADA stands or combination of base cabinets and roll out flammable storage cabinets. When the hood is not in use the flammable storage cabinet is stowed under the bases. For base cabinets refer to casework catalog.

The hood interior is constructed from white poly resin that is chemical resistant and easy to maintain. The interior baffles are fully adjustable at the top and bottom to better control airflow. It also has two access panels to get into the walls of the hood for plumbing and wiring maintenance from inside. This unit is typically used with constant volume or variable air volume exhaust systems. For more features for this hood such as alarms visit the accessories section in this catalog.

HAH STANDARD FUME HOOD SIZES

MODEL NO.	"A" WIDTH	HEIGHT	DEPTH	EXHAUST DUCT	BLOWER PRT. NO.
100-035-HAH	35"	59"	33"	8" DIAMETER	1HA-RTB-035
100-036-HAH	36"	59"	33"	8" DIAMETER	1HA-RTB-036
100-047-HAH	47"	59"	33"	9" DIAMETER	1HA-RTB-047
100-048-HAH	48"	59"	33"	9" DIAMETER	1HA-RTB-048
100-058-HAH	58"	59"	33"	10" DIAMETER	1HA-RTB-058
100-060-HAH	60"	59"	33"	10" DIAMETER	1HA-RTB-060
100-070-HAH	70"	59"	33"	10" DIAMETER	1HA-RTB-070
100-072-HAH	72"	59"	33"	10" DIAMETER	1HA-RTB-072
100-094-HAH	94"	59"	33"	2 - 10" DIA.	1HA-RTB-094
100-096-HAH	96"	59"	33"	2 - 10" DIA.	1HA-RTB-096

Note: Blowers are offered in single or three phase and optional explosion proof if needed.

Applications: Industrial, University, & K thru High School

Added Accessory options: Chain and sprocket sash, explosion proof lights and electrical fixtures, special chemical resistant coated plumbing fixtures, alarms, sash sensor w/ alarm, ceiling enclosures, pre-wire, pre-plumb, work surfaces, and sash stops. Roll out flame storage or standard storage systems on casters. Steel ADA stands and base cabinets.

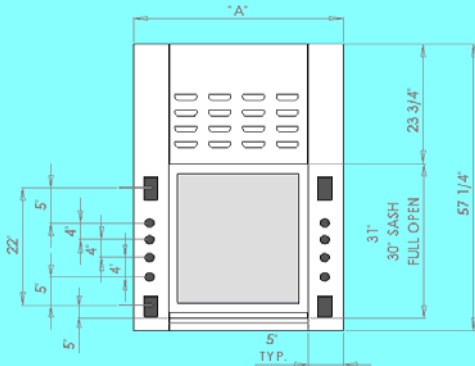

FRONT VIEW

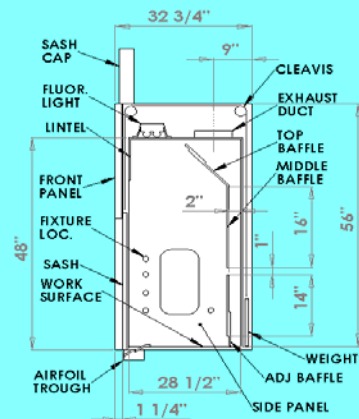

SIDE SECTION

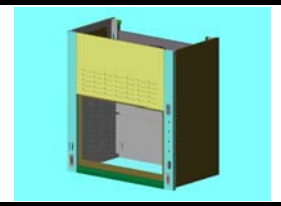

FLAT FACE AIRFOIL FUME HOODS:

The flat face style fume hood is of a double wall construction, allowing for the installation of service outlets on both sides of the hood. All the controls can be mounted on the hoods post fronts allowing for easy manipulation. The hood comes with inner and outer access panels to allow servicing of valves and electrical connections. The hood exterior is constructed of furniture steel and painted with a chemical and corrosion resistant finish. The interior is constructed of a chemical resistant white poly resin which is both durable and easy to maintain. The hoods sash is constructed of furniture steel and painted to match hood. The vertical sliding sash encases a 1/4" thick panel of laminated safety glass and uses a counterbalance weight for smooth operation. For more sash options turn to the accessories section in this catalog. This hood is standard with louvers in the front panel for constant bypass. The hood can use the Add Air System for greater energy savings for more details about this system see the accessories section in this catalog. This hood comes standard with a removable airfoil.

Services-

This hood comes standard with a two tube fluorescent light and a round exhaust duct. Optional services include light switch, blower switch, air, gas, vacuum, water, electrical receptacles, vapor proof incandescent light, and square duct. All items available along with a full selection of additional items in the accessories section in this catalog. All fume hood front posts are pierced for fixtures based on customer specifications. The hood interior liner will only have holes where fixtures are requested by customer. This hood can be used with restricted air volume exhaust, variable air volume, and constant bypass systems.

FFA STANDARD FUME HOOD SIZES					
MODEL NO.	"A" WIDTH	HEIGHT	DEPTH	EXHAUST DUCT	BLOWER PRT. NO.
100-035-FFA	35"	56"	33"	8" DIAMETER	1FA-RTB-035
100-036-FFA	36"	56"	33"	8" DIAMETER	1FA-RTB-036
100-047-FFA	47"	56"	33"	9" DIAMETER	1FA-RTB-047
100-048-FFA	48"	56"	33"	9" DIAMETER	1FA-RTB-048
100-058-FFA	58"	56"	33"	10" DIAMETER	1FA-RTB-058
100-060-FFA	60"	56"	33"	10" DIAMETER	1FA-RTB-060
100-070-FFA	70"	56"	33"	10" DIAMETER	1FA-RTB-070
100-072-FFA	72"	56"	33"	10" DIAMETER	1FA-RTB-072
100-094-FFA	94"	56"	33"	2 - 10" DIA.	1FA-RTB-094
100-096-FFA	96"	56"	33"	2 - 10" DIA.	1FA-RTB-096

Note: Blowers are offered in single or three phase and optional explosion proof if needed.

Applications: Industrial, Institutional, University, & K thru High School

Added Accessory options: Chain and sprocket sash, explosion proof lights and electrical fixtures, special chemical resistant coated plumbing fixtures, alarms, sash sensor w/ alarm, ceiling enclosures, pre-wire, pre-plumb, work surfaces. Remote baffle, sash configurations, material choice, and sash stops.

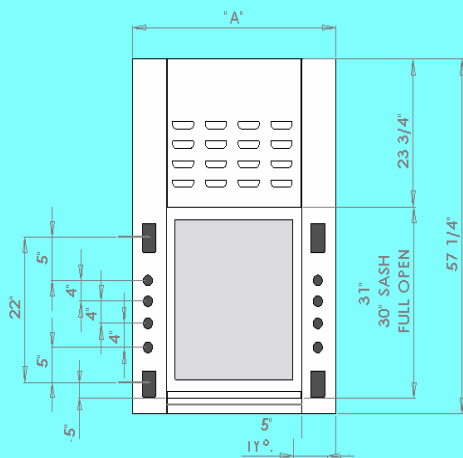

FRONT VIEW

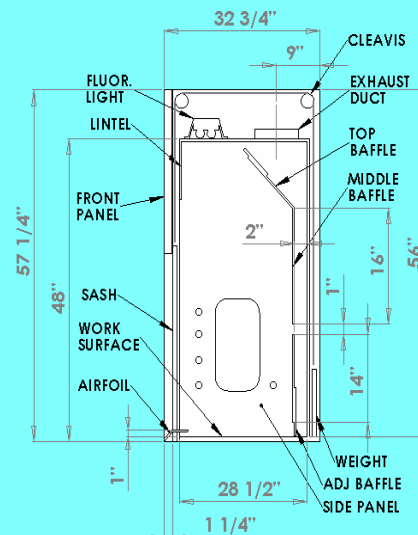

SIDE SECTION

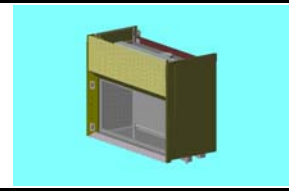

PERCHLORIC FUME HOOD:

The perchloric style fume hood is designed for working with perchloric acids. All exposed areas within the hood are constructed from 316 stainless steel that is at least 16-gauge material. The sash and the airfoil are also constructed from the same materials. This hood is like the Control Air style hood in that it has the same double walled construction for electrical and plumbing installations. The outer side panels are removable for access to plumbing and wiring. The exterior is constructed of furniture steel and painted with a corrosion and chemical resistant finish. The sash is designed to operate smoothly and has a single counter balance weight. The sash encapsulates double paned laminated safety glass that is 1/4" thick.

The interior is completely welded together including the work surface except for the baffles which are removable and adjustable. The work surface has a 1/4" dish and a trough with a 1 1/2" diameter drain that runs along the back of the hood this helps control spills and clean up. The trough is integrated into the work surface and is sloped down to the drain. All horizontal and vertical angles are covered. This hood also features a wash down system to aid in cleaning up the interior after use.

Services-

The Perchloric style hood comes standard with a two-tube fluorescent light and round exhaust duct. Optional services include a light switch, blower switch, air, gas, vacuum, water, electrical receptacles, incandescent vapor proof light, and square duct. All fixtures are optional. The post front panels are pierced based on customer request as well as fixture locations within the liner. If no fixtures or receptacles are requested with locations then no holes will be pierced in the post or liner. This hood is used in variable air and bypass air systems. For the bypass system you must use the louvered front panel when ordering this hood.

If you have questions or concerns about the addition of accessories contact your dealer representative. They will work with you to help finalize your design.

PERCHLORIC STANDARD FUME HOOD SIZES					
MODEL NO.	"A" WIDTH	HEIGHT	DEPTH	EXHAUST DUCT	BLOWER PRT. NO.
100-035-PFH	35"	57 3/4"	32 7/8"	8" DIAMETER	1PF-RTB-035
100-036-PFH	36"	57 3/4"	32 7/8"	8" DIAMETER	1PF-RTB-036
100-047-PFH	47"	57 3/4"	32 7/8"	9" DIAMETER	1PF-RTB-047
100-048-PFH	48"	57 3/4"	32 7/8"	9" DIAMETER	1PF-RTB-048
100-058-PFH	58"	57 3/4"	32 7/8"	10" DIAMETER	1PF-RTB-058
100-060-PFH	60"	57 3/4"	32 7/8"	10" DIAMETER	1PF-RTB-060
100-070-PFH	70"	57 3/4"	32 7/8"	10" DIAMETER	1PF-RTB-070
100-072-PFH	72"	57 3/4"	32 7/8"	10" DIAMETER	1PF-RTB-072

Note: Blowers are offered in single or three phase, this model uses SPARK RESISTANT/ EXPLOSION PROOF models only.

Applications: Industrial, Institutional, & University

Added Accessory options: Chain and sprocket sash, explosion proof lights and electrical fixtures, special chemical resistant coated plumbing fixtures, alarms, sash sensor w/ alarm, ceiling enclosures, pre-wire, pre-plumb, sash stops.

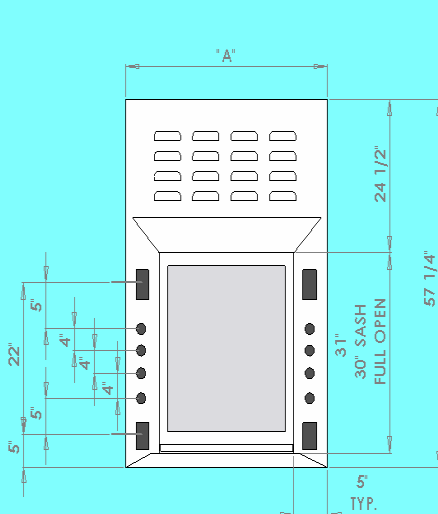

FRONT VIEW

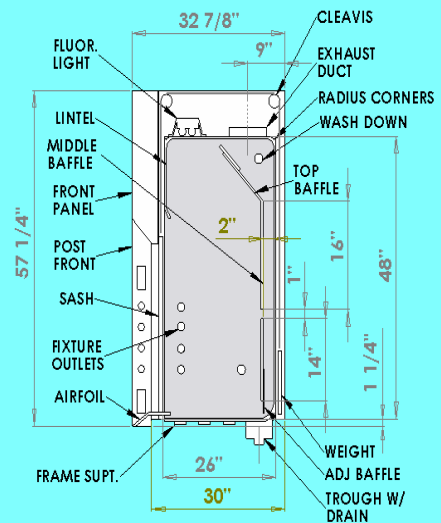

SIDE VIEW

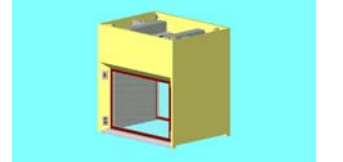

PASS THROUGH FUME HOOD:

This hood is designed to allow the operator or operator's access to the hoods work surface from both sides of an island counter top. The hood has applications for use in teaching institutions and where ever dual access can aid in the labs layout and use. The hood exterior is constructed of furniture steel and painted with a corrosion resistant finish. The interior is constructed of a chemical resistant white poly resin. A 2' two-tube fluorescent light in 2 locations is standard along with the two painted steel sash and centered exhaust duct. This fume hood is used in restricted air volume exhaust systems, constant bypass, and variable air volume systems.

Services –

This unit typically does not offer many accessories because the lack of wall space within the hood. However fixtures can be deck mounted with the remote control mounted in the supporting casework. Options include an incandescent vapor proof light, light switch, blower switch, electrical receptacles, and deck mounted fixtures.

PASS THROUGH STANDARD FUME HOOD SIZES

MODEL NO.	"A" WIDTH	HEIGHT	DEPTH	EXHAUST DUCT	BLOWER PRT. NO.
100-047-PTH	47"	57 3/4"	35 3/4"	9" DIAMETER	1PT-RTB-047
100-048-PTH	48"	57 3/4"	35 3/4"	9" DIAMETER	1PT-RTB-048
100-058-PTH	58"	57 3/4"	35 3/4"	10" DIAMETER	1PT-RTB-058
100-060-PTH	60"	57 3/4"	35 3/4"	10" DIAMETER	1PT-RTB-060
100-070-PTH	70"	57 3/4"	35 3/4"	10" DIAMETER	1PT-RTB-070
100-072-PTH	72"	57 3/4"	35 3/4"	10" DIAMETER	1PT-RTB-072

Note: Blowers are offered in single or three phase and optional explosion proof if needed. Single phase Draw is 115V. 60Hz. Typical.

Also note that CA style post configuration shown can be changed to a Flat Face option if requested.

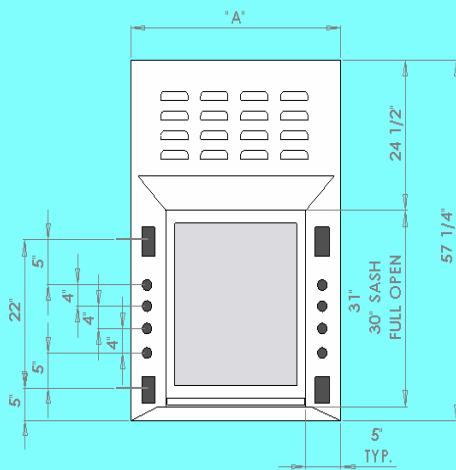

FRONT VIEW

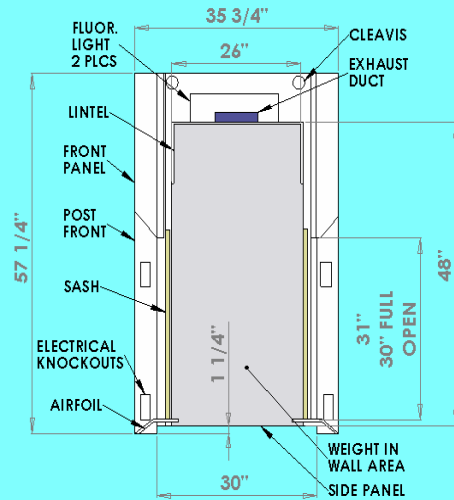

SIDE VIEW

Through Type Hood is offered with two type of post configurations the CA style as shown and the FF style. Bear in mind if you select the FF style post you lose the airfoils and the sash closes on the work surface. The two sash operate independent of one another with the counterbalance weight occupying the wall space on both sides. This in turn limits the space for installing plumbing fixtures. If plumbing fixtures are needed mount on work surface with remote control through the supporting casework or base. Even with the reduced space in the walls there is typically plenty of room for mounting electrical fixtures such as light switch and duplexes. The sash can be locked for limiting access from one or the other, this works well for classroom environments. For other options pertaining to this product and other hoods see the accessories section.

Besides being mounted on an island in a lab this unit can also be mounted between two rooms or two controlled environments. It can also be mounted on one of our bases with a roll out cabinet for extra storage if needed. As with all our product lines this is also customizable to fit your needs.

Applications: Industrial, Institutional, University, & K thru High School

Added Accessory options: Explosion proof lights and electrical fixtures, special chemical resistant coated plumbing fixtures one side only, alarms, sash sensor w/ alarm, ceiling enclosures, pre-wire, pre-plumb, work surfaces. sash configurations, material choice, and sash stops.

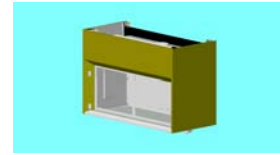

RADIO ISOTOPES HOOD:

The radio isotopes hood is based on the CA style hood in that it utilizes the airfoil fascia. The exterior is constructed of furniture steel and painted with a corrosion resistant finish. This hood also uses the double wall construction to permit the installation of electrical and plumbing fixtures within the hood. The RI hood has removable sealed access panels inside the working area and externally by removing the outer side panels.

The major difference in this hood is the interior and its construction. The RI fume hood is specifically designed to help protect the operator while working with radio-active materials. The interior liner is constructed from type 304 stainless steel that is 16-gauge and finished to a number 4 grade. The interior is completely welded including the counter top work surface. The counter top is dished to help capture spills and also has an integral 3"x6" cup sink with drain. All corners and horizontal joints to have at least a 3/4" radius, this helps with interior cleanup and decontamination. The interior baffles are removable and fully adjustable and are also 304 stainless steel. The complete sash along with the airfoil are also 304 stainless steel. The sash operates smoothly with a single counter balanced weight.

Services-

The Radio Isotopes style hood comes standard with a two tube fluorescent light and round exhaust duct. Optional services include a light switch, blower switch, air, gas, vacuum, water, electrical receptacles, and an incandescent vapor proof light. All fixtures are optional. The post fronts are pierced based on customer request as well as fixture locations within the liner. If no fixtures or receptacles are requested with locations then no holes will be pierced in the post or liner. This hood is used in variable air and bypass air systems.

For the bypass system louvers are punched into the front panel to allow a constant source of air flow into the fume hood when the sash is closed. The air is allowed to flow over the sash and then into the hood to be exhausted out. For more information on the RIH fume hood contact Labcase directly for your answers.

RADIO ISOTOPES STANDARD FUME HOOD SIZES					
MODEL NO.	"A" WIDTH	HEIGHT	DEPTH	EXHAUST DUCT	BLOWER PRT. NO.
100-035-RIH	35"	57 3/4"	32 7/8"	8" DIAMETER	1RH-RTB-035
100-036-RIH	36"	57 3/4"	32 7/8"	8" DIAMETER	1RH-RTB-036
100-047-RIH	47"	57 3/4"	32 7/8"	9" DIAMETER	1RH-RTB-047
100-048-RIH	48"	57 3/4"	32 7/8"	9" DIAMETER	1RH-RTB-048
100-058-RIH	58"	57 3/4"	32 7/8"	10" DIAMETER	1RH-RTB-058
100-060-RIH	60"	57 3/4"	32 7/8"	10" DIAMETER	1RH-RTB-060
100-070-RIH	70"	57 3/4"	32 7/8"	10" DIAMETER	1RH-RTB-070
100-072-RIH	72"	57 3/4"	32 7/8"	10" DIAMETER	1RH-RTB-072

Note: Blowers can be ordered single or three phase and optional explosion proof as required by the customer. Single phase draw is 115V. 60Hz. Typical.

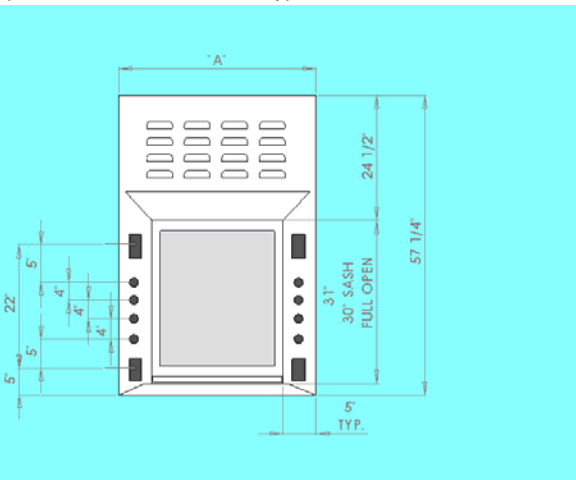

FRONT VIEW

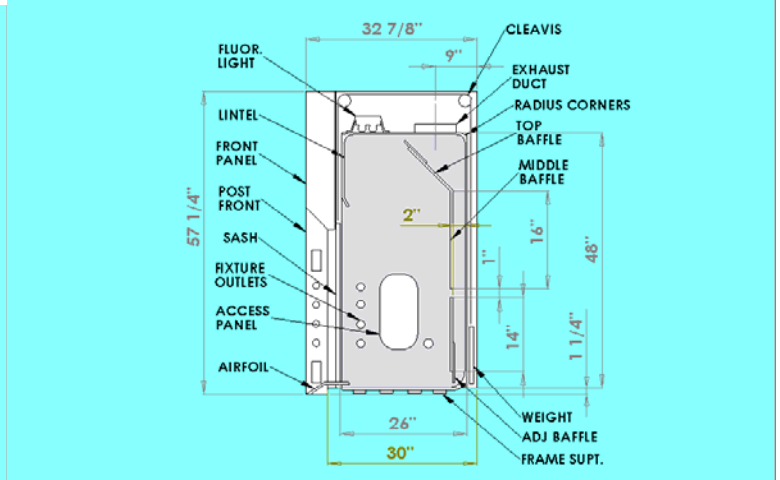

SIDE VIEW

Applications: Industrial, Institutional, & University

Added Accessory options: Chain and sprocket sash, explosion proof lights and electrical fixtures, special chemical resistant coated plumbing fixtures, alarms, sash sensor w/ alarm, ceiling enclosures, pre-wire, pre-plumb, sash configurations, and sash stops.

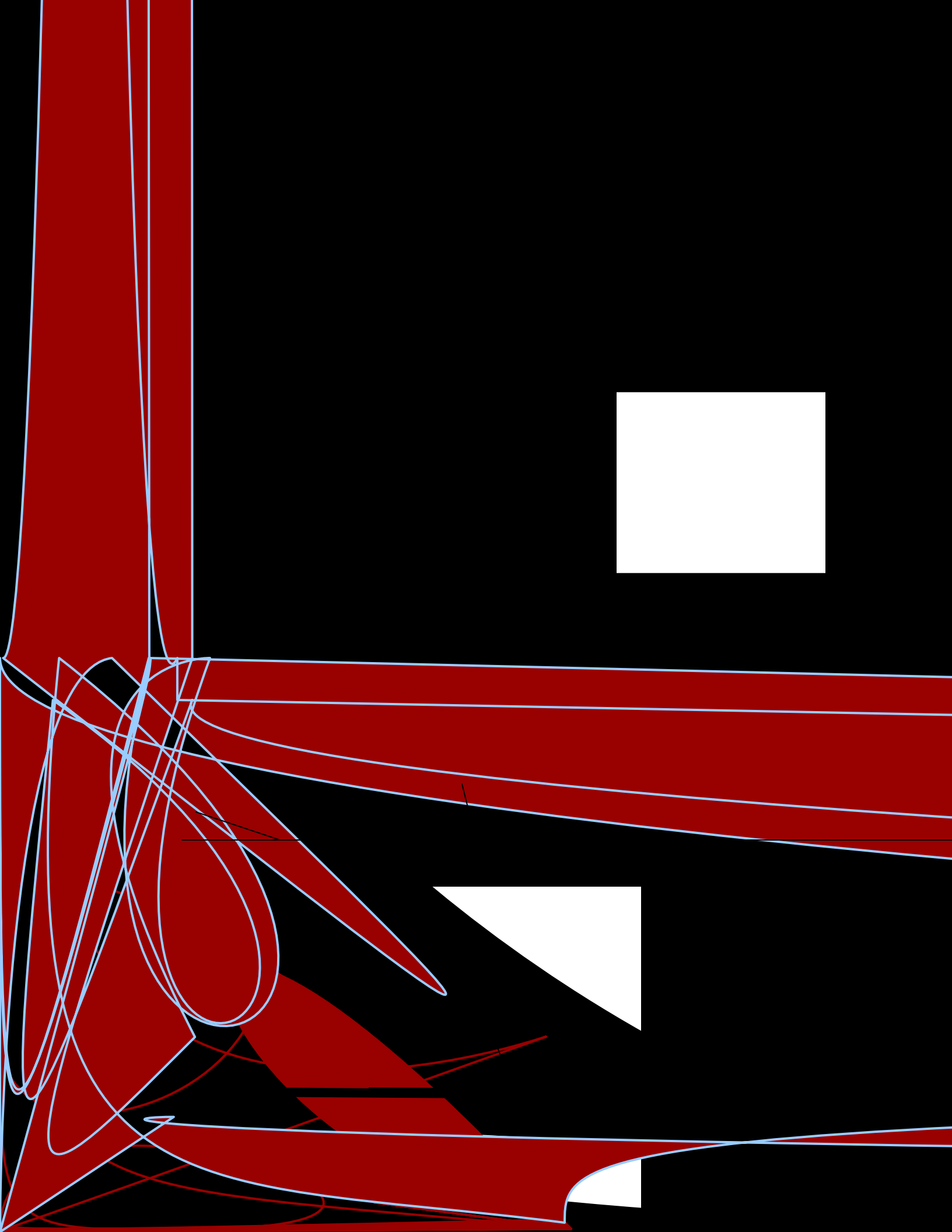

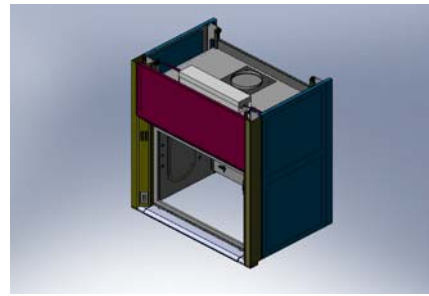

Interceptor™ Fume Hoods (High performance)

The Interceptor™ series hoods utilize a 45 degree front fascia along with smooth radius formed components to eliminate air turbulence. The result is improved performance and above all safety for the operator. This model fume hood also utilizes our new low profile ergonomically designed front airfoil. The airfoil is flush with the work surface and can be flipped up for containment tray removal or for general cleaning. This design is also easily removable for complete disassembly. The interior lining is a U.L. approved material designed to remove heavier and lighter than air fumes. Baffle positions are fixed with no moving or adjustable components. This design helps maintain safety and a consistent performance for years of carefree service. Flow rates run from 125 down to 60 LFP based on blower settings and flow requirements. The exterior of the hood is fabricated out of cold rolled steel and finished with an acid wash and then powder coated. The frame is a laser cut two component galvanized steel module. The modularity allows for field assembly or easy disassembly.

Standard features of this hood are designed to add strength and stability and esthetics. Most parts on this fume hood are universal from left to right and from model size to model size. There are no exposed steel fasteners in this hood or on the exterior. The fluorescent lighting system is a T-8 type fixture with an enlarged light strip opening to improve interior illumination. This model fume hood uses a 10" round exhaust duct collar. The airfoil is offered in stainless steel along with the powder coated steel version. The removable containment drip tray will be manufactured out of type 304 stainless steel.

The sash is a powder coated steel or type 304 stainless steel vertically sliding sash. This hood can also utilize a vertical and horizontal sliding sash system as well. All sashes are fitted with ¼" thick laminated safety glass panel or panels depending on model size. The standard vertical sliding sashes seal the glass in a frame that is able to be disassembled. The combo sash uses a trimmed version of the safety glass.

All sashes are attached to a counterbalance weight via coated aircraft cable. The heavy gauged stn. Stl. coated cable rides on corrosion resistant quiet operation pulleys.

All fume hoods are shipped pre-wired and fixtures installed when requested. Pre-plumbing is an option. Standard sizes: "A" = 47", 48", 58", 60", 70", 72", 84", 94", & 96"

Standard features:

- Louvered front panel
- Powder coat finish with standard colors
- Poly Resin liner
- Removable ergonomically designed airfoil
- T-8 Fluorescent light
- Modular frame construction
- Alarm AFA500

Special Features when required:

- Low velocity interior liner
- Add air chambers
- Special bases (mobile)
- VAV integrated systems
- Sash positioning devices

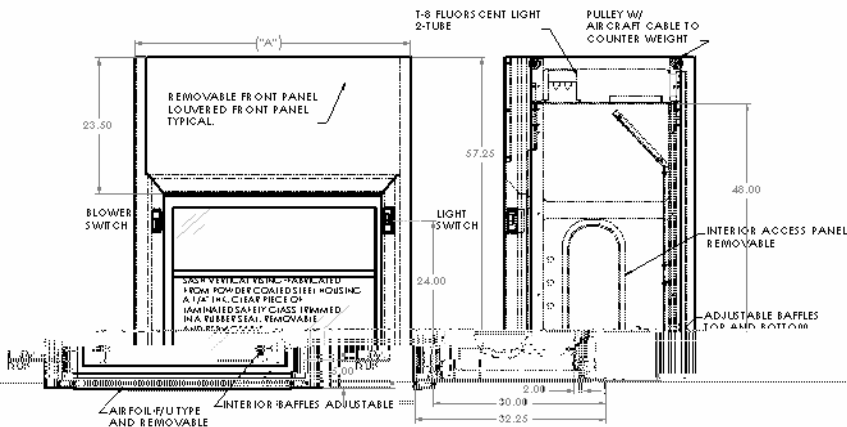

FRONT VIEW

SIDE VIEW

INTERCEPTOR STANDARD FUME HOOD SIZES

MODEL NO.	"A" WIDTH	HT	DEPTH	EXHAUST DUCT
100-035-IFH	35"	57.25"	34"	8" DIAMETER
100-036-IFH	36"	57.25"	34"	8" DIAMETER
100-047-IFH	47"	57.25"	34"	9" DIAMETER
100-048-IFH	48"	57.25"	34"	9" DIAMETER
100-058-IFH	58"	57.25"	34"	10" DIAMETER
100-060-IFH	60"	57.25"	34"	10" DIAMETER
100-070-IFH	70"	57.25"	34"	10" DIAMETER
100-072-IFH	72"	57.25"	34"	10" DIAMETER
100-094-IFH	94"	57.25"	34"	2 - 10" DIA.
100-096-IFH	96"	57.25"	34"	2 - 10" DIA.



Student Station fume hoods

The constant exhaust student stations are designed to protect the instructor and students while providing an open work space with plenty of viewing area. The outer structure is a powder coated finish furniture grade steel. This also includes the sash assembly unless specified. The sash encapsulates ¼" thick laminated safety glass trimmed in a neoprene channel and is removable if damaged. The sash is connected to a dual counter weight system using aircraft style coated cables or chain driven. The airfoil is typically type 304 stainless steel designed ergonomically to perform and be easily removable for cleaning.

The interior is a combination of stainless steel plenums and white polyresin material. The lighting is typically a fluorescent light that is a U.L. approved type fixture sealed from the interior. Fixtures – both plumbing and electrical options are available. Note the base cabinets or special designed bases are set up to handle accessories.

Testing – Hoods are designed to meet ASHRAE 110-1995 & SAMA standard LF-10.

Options- ADA containment trough, add air chambers, sash, liners, pass thru, and accessories

Note – these systems can be daisy chained together side by side or back to back.

Sizes: 47", 48", 58", 60", 70", & 72" width models

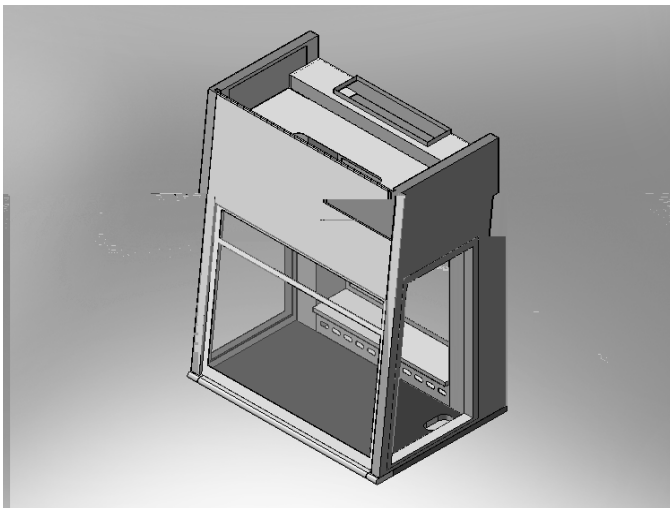
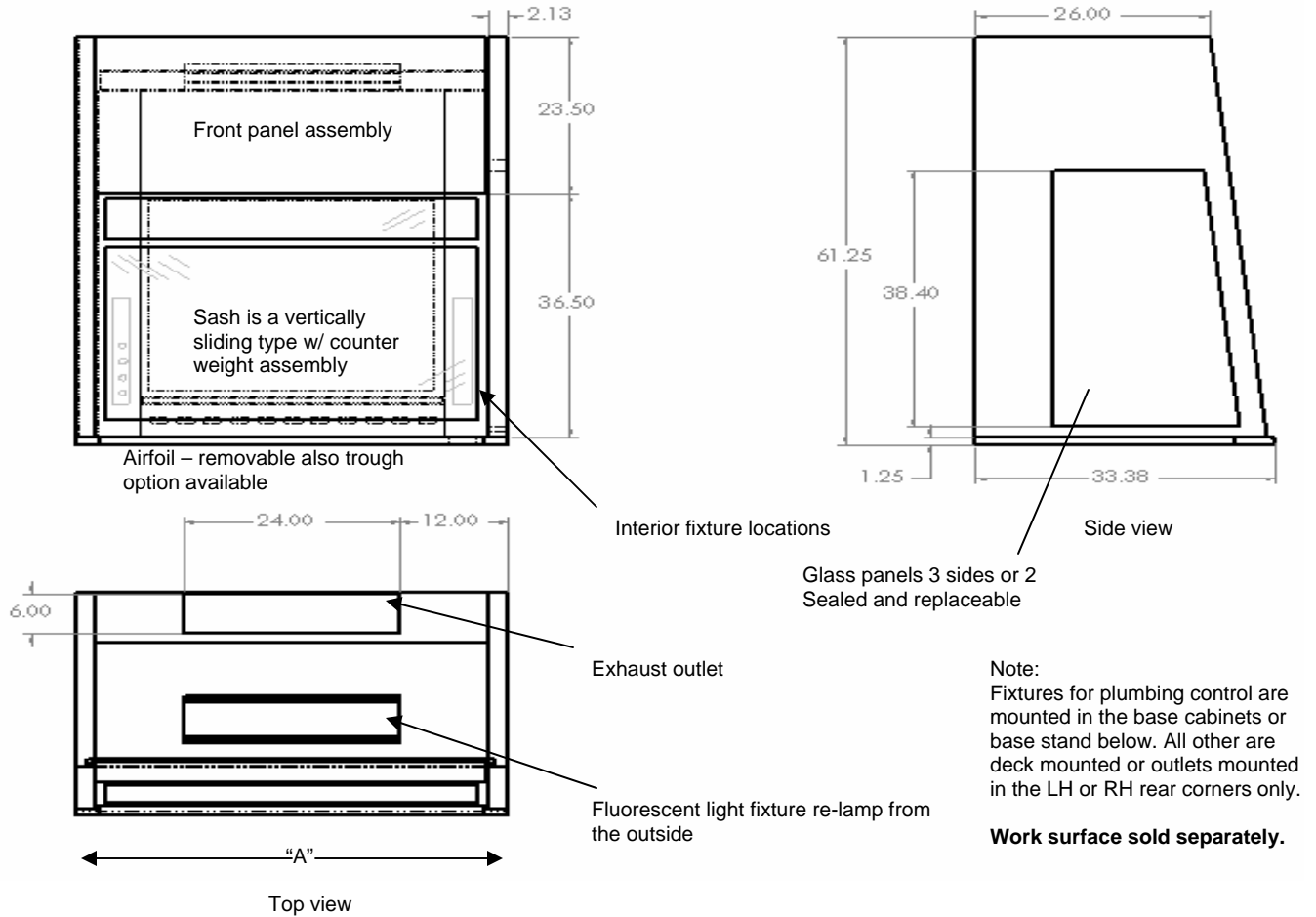

Student Station using standard construction

STUDENT STATION STANDARD FUME HOOD SIZES

MODEL NO.	WIDTH	HT	DEPTH	EXHAUST DUCT
100-047-SFH	47"	60"	33-3/8"	6" X 24"
100-048-SFH	48"	60"	33-3/8"	6" X 24"
100-058-SFH	58"	60"	33-3/8"	6" X 30"
100-060-SFH	60"	60"	33-3/8"	6" X 30"
100-070-SFH	70"	60"	33-3/8"	6" X 36"
100-072-SFH	72"	60"	33-3/8"	6" X 36"

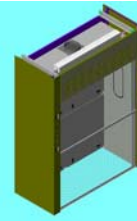

WALK-IN FUME HOOD:

The walk-in style fume hood is constructed of furniture steel and painted with a corrosion resistant finish. The large front sash lend themselves to be useful when larger equipment is being used, the hood allows roll in and out access. The hood design is similar to the Control Air style hood with its double walled construction for plumbing and electrical installations. This unit utilizes duel sash that operate independently of each other. Each sash houses a 1/4" laminated safety glass panels that are encapsulated in a steel frame painted to match the hood. Each sash uses its own independent single counter balance weight for smooth and reliable operation.

The interior is constructed out of a white poly resin that is both chemical resistant and easy to maintain. The interior baffle configuration allows for adjustment at the top, center, and bottom.

Services-The WI style hood comes standard with a two tube fluorescent light and round ducts. Optional services include an incandescent vapor proof light, light switch, blower switch, air, gas, vacuum, water, electrical receptacles, and square duct when specified. Also wall mount cup sinks are available for this hood type. Fixture configurations are optional based on customer needs. The access panels in the post front are pierced based on the customers request otherwise there will be no cutouts. The hood liner is also pierced in pre-identified locations based on request otherwise the liner will not have holes. For more options and to add items to this style hood look in the accessories section in this catalog. This hood is used in variable air and bypass air systems.

When the hood is used in a constant volume system the front panels must have louvers pierced through for more airflow. This is especially true when the sash is closed and the air flows over the top of the sash and through the hood.

WALK-IN STANDARD FUME HOOD SIZES

MODEL NO.	"A" WIDTH	HEIGHT	DEPTH	EXHAUST DUCT	BLOWER PRT. NO.
100-035-WIH	35"	93"	32.875"	8" DIAMETER	1WI-RTB-035
100-036-WIH	36"	93"	32.875"	8" DIAMETER	1WI-RTB-036
100-047-WIH	47"	93"	32.875"	9" DIAMETER	1WI-RTB-047
100-048-WIH	48"	93"	32.875"	9" DIAMETER	1WI-RTB-048
100-058-WIH	58"	93"	32.875"	10" DIAMETER	1WI-RTB-058
100-060-WIH	60"	93"	32.875"	10" DIAMETER	1WI-RTB-060
100-070-WIH	70"	93"	32.875"	10" DIAMETER	1WI-RTB-070
100-072-WIH	72"	93"	32.875"	10" DIAMETER	1WI-RTB-072
100-094-WIH	94"	93"	32.875"	2 - 10" DIA.	1WI-RTB-094
100-096-WIH	96"	93"	32.875"	2 - 10" DIA.	1WI-RTB-096

Note: Blowers are sold in single or three phase electrical options and explosion proof if required. Single phase draw is 115V. 60Hz. typical.

Applications: Industrial & University

Added Accessory options: explosion proof lights and electrical fixtures, special chemical resistant coated plumbing fixtures, alarms, sash sensor w/ alarm, ceiling enclosures, pre-wire, pre-plumb, work surfaces. Lattice racks, sash configurations and material choice, cup sinks, floor pans, and sash stops.

The WI type fume hood can also be ordered with the Control Air post configuration. Alarms can be ordered along with the standard complement of fixtures which include cup-sinks, gooseneck, down spout, angle and strait connections. A countertop can also be ordered for the hood that either folds up or is slid into place. Another option not included in the accessories section of this catalog is a floor capture tray made of stainless steel or painted furniture steel, the tray is designed to contain spills. For more special features pertaining to your needs contact Labcase for the answers.

One of the more common add on features that are special pertain to adding a countertop to the hoods interior. The counter top is constructed to swing down out of the way when it is not needed. This design allows the end user another degree of control when utilizing the interior hood space.

And for those locations where the possibility of an earthquake is apparent we offer a wall mount adjustable bracket system. This allows the contractor to secure the hood into position and greatly reduce the possibilities of a fume hood structure falling over or vibrating out of position. If you have any questions concerning the items displayed or discussed within this catalog contact your dealer representative.

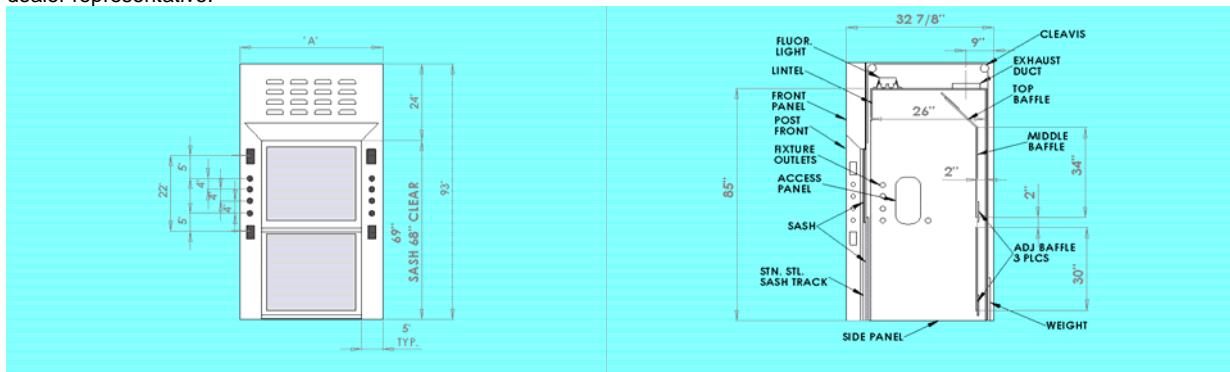

FRONT VIEW

SIDE VIEW

ADA STANDS

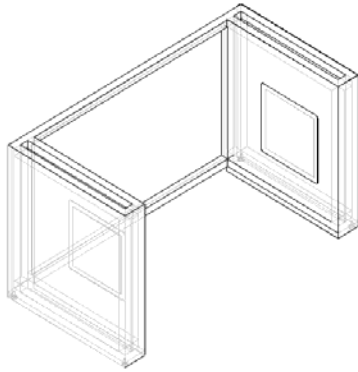

DESIGN 1 STANDARD ADA STAND		SIZES			
MODEL NO.	WIDTH	HEIGHT	DEPTH	ADJUSTABLE FEET	MATERIAL
190-035-SD1	35"	35 1/4"	29"	STANDARD	CRS
190-036-SD1	36"	35 1/4"	29"	STANDARD	CRS
190-058-SD1	47"	35 1/4"	29"	STANDARD	CRS
190-060-SD1	48"	35 1/4"	29"	STANDARD	CRS
190-058-SD1	58"	35 1/4"	29"	STANDARD	CRS
190-060-SD1	60"	35 1/4"	29"	STANDARD	CRS
190-070-SD1	70"	35 1/4"	29"	STANDARD	CRS
190-072-SD1	72"	35 1/4"	29"	STANDARD	CRS

STANDS FOR FUME HOODS:

The fume hood stands are designed with strength and durability in mind to support the hoods superstructure. The stands are constructed of 16 gauge furniture steel or number 304 stainless steel. There are three different designs to choose from as you will see below. Choose the design that best fits your needs. If you do not see a base that will work for your needs contact your dealer and we can work with you on your own unique design. All bases painted to match fume hoods unless requested or is constructed from stainless steel.

VALUE ADDED FEATURES -

Stands can be mounted with electric power height adjustment if desired. These stands can also use a hand crank type height adjusting system. They can go from 30" high up to 40". These are currently special add on items just ask and we can add this to the base as needed. (note typically used with safety cabinet)

You can also add one other option to the bases and that would be casters. There are both 4" dia and 5" diameter gray colored casters locking or non-locking, non-marking, full 360 degree swivel institutional grade NSF approved. For further details on added value items contact your dealer for further ordering details.

BASE AND GALVANIZED COUNTERTOP FOR A 24" SPRAYBOOTH

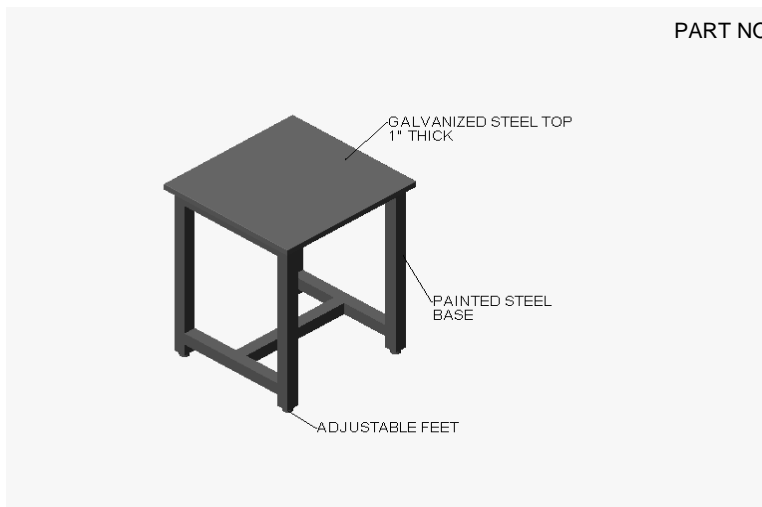

PART NO. **124-BAS-GLV** = 24"W X 30"H X 30"D
130-BAS-GLV = 30"W X 30"H X 30"D
136-BAS-GLV = 36"W X 30"H X 30"D
148-BAS-GLV = 48"W X 30"H X 30"D

Bases and stands are designed to meet ADA requirements when requested. Bases have options for NSF approved casters non-marking type. Also bases for fume hoods are designed to allow roll out storage bases to fit along with built in storage where needed. For more details on specific designs or options contact your dealer or representative.

FUME REMOVAL SYSTEMS: Bench Top

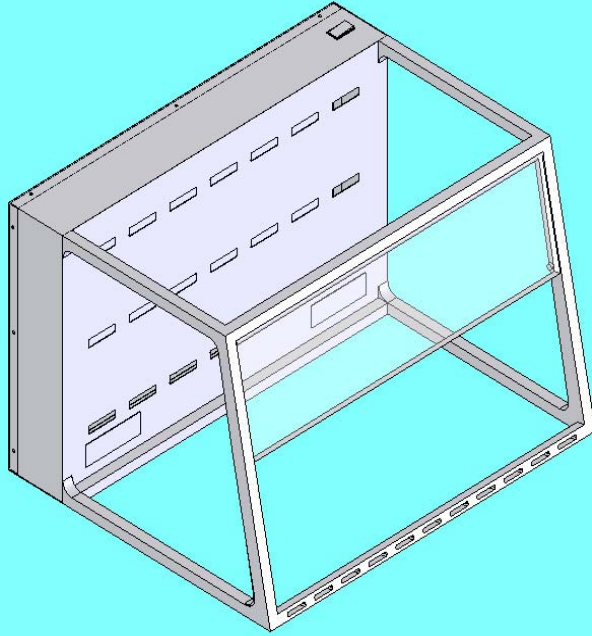

VENTILATION STATION EXTRACTOR SYSTEM –

This system works well in class rooms for clear viewing from all three sides. It has a built in filtration system completely removable and has its own blower. The air is discharged out the back of the system. It can discharge into the room or it can also be ducted out to discharge into the environment. Duct sold separately. The body is manufactured from CRS typically 18 gauge and is powder coated white. The view windows are all sealed in frames. The windows themselves are ¼" thick clear acrylic including the swing open front panel. This allows for easy material loading and unloading as needed. Electrical outlets can be provided on the inside as needed. This model comes with filter, blower, and 8' power cord.

Standard Features:

- 6" diameter exhaust duct with 1" collar
- Integrated airfoil front frame
- Outlet locations punched as needed
- Easy access into blower compartment
- 8' power cord
- Toggle type blower switch
- Flip up front sash for easy loading
- Optional cart mounting
- Built in blower
- Carbon charged filter

Above: MODEL NUMBER **100-036-VTS**

Each model comes with 8' cord standard plug configuration all Models use 115V. outlet for power source.

Model # **100-036-VTS** this complete system is 29" deep, 24" high, and 36" wide

Model # **100-024-VTS** this complete system is 29" deep, 24" high, and 24" wide

Below: MODEL NUMBER **100-FAC-028**

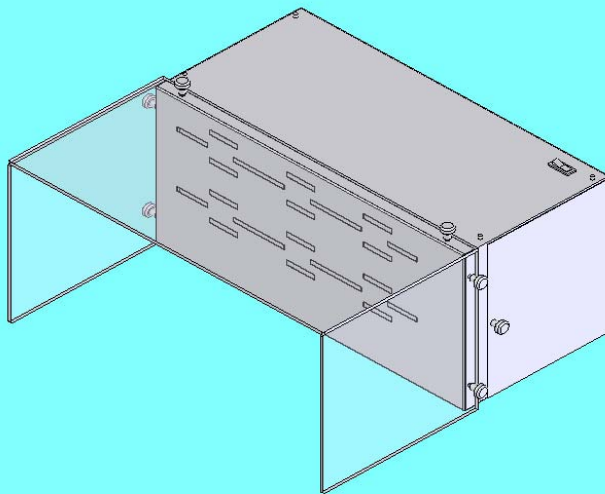

FUME ABSORBER SYSTEM –

This system is manufactured to provide odor relief during manufacturing processes. Typical applications include xylene and toluene exposure. With the absorbers carbon charged filter system and built in blower it is a clean safe way to protect your employees from over exposure. Filters are easily changed by accessing the filter compartment in the back. The clear acrylic view windows can be removed or configured as needed to provide the best possible working environment. The body of the absorber is manufactured from 18 gauge white powder coated furniture steel. The power on off switch is a lighted toggle type located at the top of the unit. This system discharges the air back into the same space after the odor purging process.

Standard Features:

- Filter carbon charged type
- 8' power cord
- Removable shield
- Toggle on / off switch illuminated
- Built in blower

Model # **100-028-FAC** this complete system is 26" deep, 13" high, and 28 ½" wide

Model # **100-012-FAC** this complete system is 26" deep, 13" high, and 12 ½" wide

CH1

CANOPY HOODS:

The canopy hood is designed to collect heat, steam, and various fumes over the work surface. The hood is typically mounted over the work surface area attached to the wall (model CH1). This model also has two suspended rod brackets welded to the front for support. The second model is the CH2 or Island version of canopy hood. Canopy hoods are constructed from furniture grade steel and are powder coated with a corrosive resistant finish. Canopy hoods can also be fabricated from stainless steel type 304. The canopy hood utilizes an internal baffle that can support a fluorescent or incandescent light depending on preference. The interior baffle when applicable is constructed from white poly resin, or stainless steel. All final connections by respective trades.

Note: We offer to modify our canopy hoods to best fill your needs.

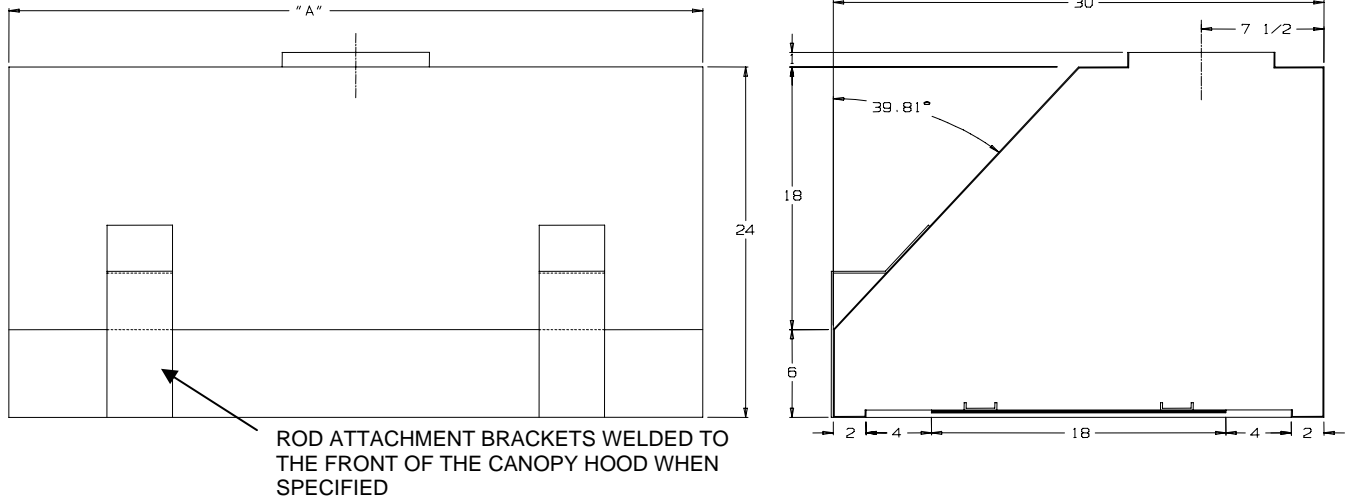

Applications: K thru High School, industrial, and Tech Schools

Added Accessory options: Explosion proof lights, fluorescent lights, vapor proof incandescent light fixtures, and baffle materials.

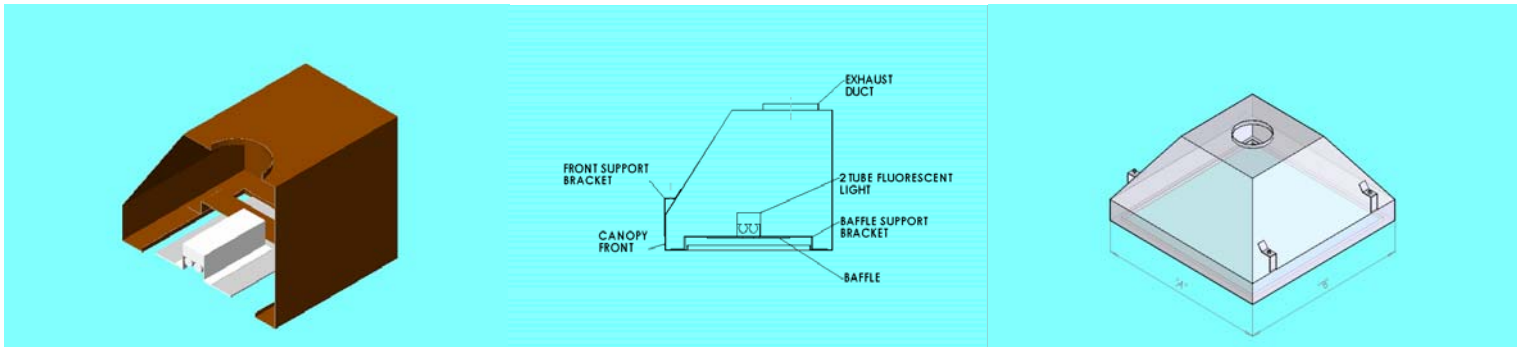

CH1 CANOPY HOOD CROSS SECTION

CH2 CANOPY HOOD

Note:

When specifying your canopy hood make sure to identify if you have a wall mount type CH1 or island type canopy hood CH2. With or without sloping sides? All canopy hoods will be offered with suspended threaded rod capabilities. The suspension rods can be supplied when specified. Or will be supplied by others based on customers needs. Some wall mount canopy hoods will also require threaded rod.

Rods – Threaded sold in 3', 4', 6', 8', & 10' sections all 3/8 course type thread unless specified or supplied differently:

3' part number = **TSR-036-S** for stainless steel add **-SS to part number**

4' part number = **TSR-048-S**

6' part number = **TSR-072-S**

8' part number = **TSR-096-S**

10' part number = **TSR-120-S**

Canopy Hood Sizes "A": 30", 35", 36", 47", 48", 58", 60", 70", 72", 84", 94", 96" and special sizes are available.

Part # starts with 150-CH1-0?? ?? = SIZE or "A" DIMENSION



SPRAY BOOTHS:

The spray booth is designed for non-toxic applications where fume removal is needed. The booths are constructed out of 18-gauge furniture steel and painted with a corrosion resistant finish. The spray booth utilizes a large particulate filter that is easy to replace. The unit includes one incandescent vapor proof light and filter.

Services- The spray booth offers four options they include a blower switch, light switch, electrical receptacles, and blowers. Note blower can also be remotely mounted.

SPRAY BOOTH STANDARD HOOD SIZES				
MODEL NO.	"A" WIDTH	HEIGHT	DEPTH	EXHAUST DUCT
100-024-SBH	24"	48"	24"	8" DIAMETER
100-030-SBH	30"	48"	24"	8" DIAMETER
100-036-SBH	36"	48"	24"	9" DIAMETER



MOBILE VENTILATION STATION HOODS:

The modular style fume hood is designed to be a mobile encapsulated work surface. This unit allows the end user the flexibility of moving the unit where it is needed, from classroom to classroom or within the lab. This mobile feature also gives the unit the flexibility to be stowed away when not in use.

The hood is constructed of furniture steel and painted with a chemical resistant finish. The frame is 16 gauge square steel tube welded together with trimmed out clear safety glass walls all framed. One side of the hood has a vertical rising type sash that is suspended with aircraft cable and a counter weight. The upper cap encloses the blower and dual tube fluorescent light. The fan outlet is perforated at the top and allows for a flexible duct connection. The unit has four independently locking wheels and a 1" or 1-1/4" thick black epoxy resin counter top. The frame can be painted to match top or be constructed from type 304 stainless steel. The work surface can also be manufactured from type 304 stainless steel if required otherwise epoxy or phenolic resin is used.

Services-

The mobile hood comes standard with a light switch, blower switch, 2 GFI duplex, filter monitor, and TELAF1001BSC safety air flow monitor. Also as a standard features the 8' electrical cord, blower, and fluorescent light. The optional features are plumbing. Flex hose can also be provided with this system for the quick disconnects. Also if internal recirculation is not needed we offer an exhaust duct connection. This can be permanent or quick disconnect type.

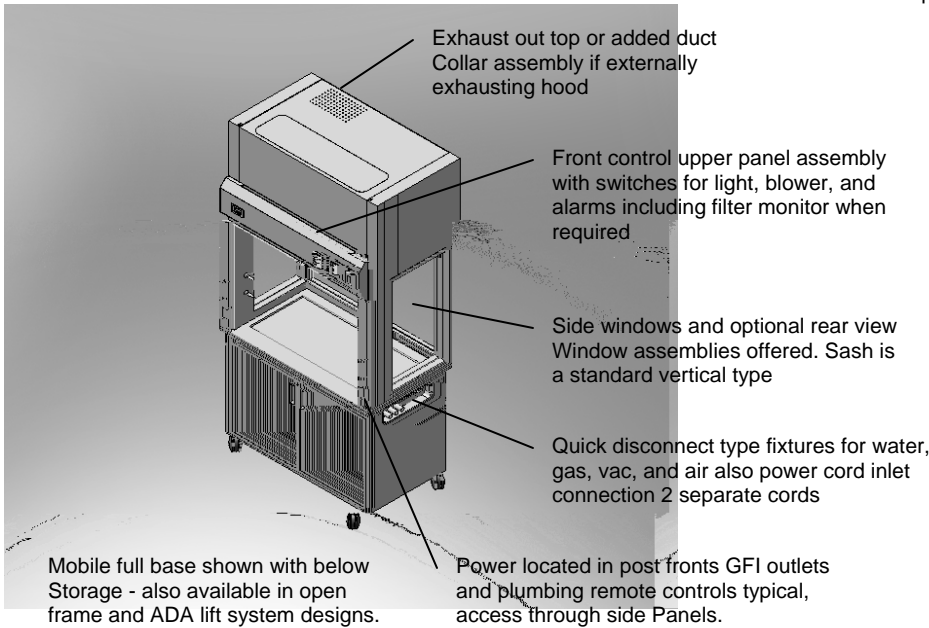

General information:

These hoods are designed to use both HEPA and carbon charged filters. We also combine both types of filters to better protect the end users. We offer filters carbon charged with added features to better contain various chemicals. See below for greater details.

MOBILE VENTILATION STATION FUME HOOD SIZES						
MODEL NO.	"A" WIDTH	HT	DEPTH	NO FILTER EXHAUST DUCT	BLOWER	BL MOTOR
100-035-MVS	35"	92"	29"	8" DIAMETER	YES	1P 120V 60HZ
100-036-MVS	36"	92"	29"	8" DIAMETER	YES	1P 120V 60HZ
100-047-MVS	47"	92"	29"	9" DIAMETER	YES	1P 120V 60HZ
100-048-MVS	48"	92"	29"	9" DIAMETER	YES	1P 120V 60HZ
100-058-MVS	58"	92"	29"	10" DIAMETER	YES	1P 120V 60HZ
100-060-MVS	60"	92"	29"	10" DIAMETER	YES	1P 120V 60HZ
100-070-MVS	70"	92"	29"	10" DIAMETER	YES	1P 120V 60HZ
100-072-MVS	72"	92"	29"	10" DIAMETER	YES	1P 120V 60HZ

FUME HOOD ACCESSORIES

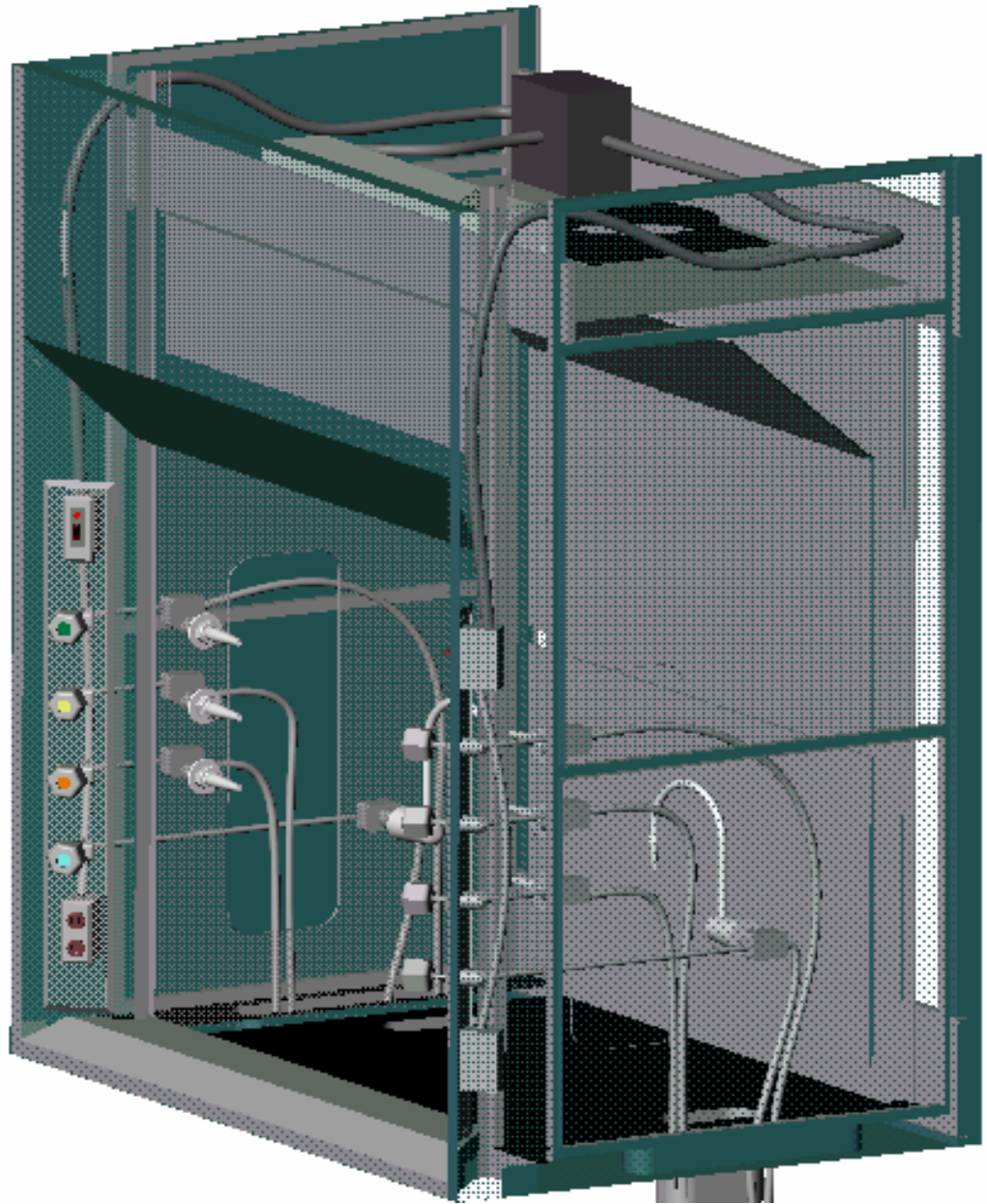

TYPICAL CA PRE-WIRED & PLUMBED

ACCESSORIES FOR FUME HOODS:

SERVICES-

Turreted gooseneck: Assemblies with removable hose feature- this fixture is chrome plated brass or colored and supplies the fume hood with water. The 3/8" angle valve with remote control is either set up for the 45° face of the Control Air fume hood or Flat Face hoods. The rods extend the handles beyond the hood front for comfortable use.



GOOSENECK PART NO. F-621
ADD -VB FOR VACUUM IF NEEDED



Hose connected turret: This device delivers water to the hood interior. The fixture is chrome plated or painted brass with 3/8" angle valve with remote control rod. This fixture can be used in most hoods from Flat Face to Control Air types.

Strait or Angled connections: These devices are used for air, gas, or vacuum applications. The fixtures are chrome plated or painted brass with 3/8" angle or strait valve. As with all fixtures the rods are long enough to allow comfortable usage of the devices when installed in the fume hood.

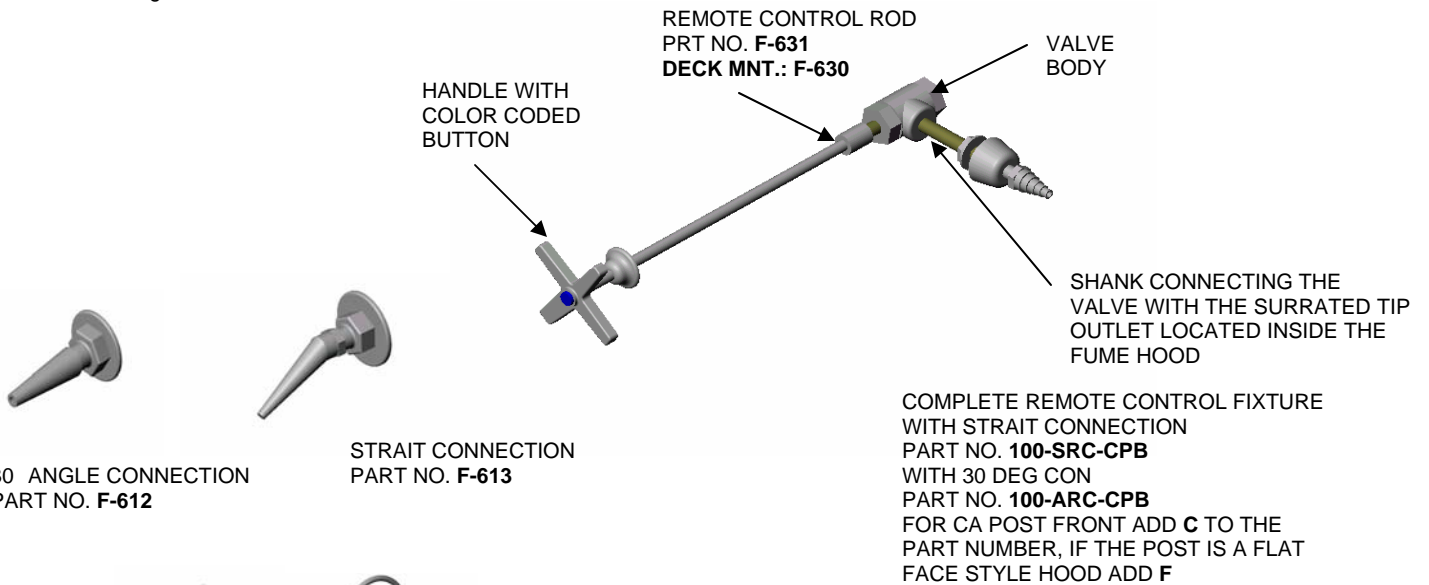

30 ANGLE CONNECTION PART NO. F-612

STRAIT CONNECTION PART NO. F-613

COMPLETE REMOTE CONTROL FIXTURE WITH STRAIT CONNECTION PART NO. **100-SRC-CPB** WITH 30 DEG CON PART NO. **100-ARC-CPB** FOR CA POST FRONT ADD C TO THE PART NUMBER, IF THE POST IS A FLAT FACE STYLE HOOD ADD F

FLANGE CONNECTOR LOCATED INSIDE HOOD # F-200



DECK MOUNTED REMOTE CONTROL OPERATED CW GOOSENECK RIGID SWING FAUCET PART NO. **F-620** IF VACUUM BREAKER IS REQUIRED ADD -VB TO END OF THE PART NUMBER



HOT AND COLD WATER MIXING W/ GSNK MODEL # F-2??



COLD WATER DOWN SPOUT MODEL # F-2??

NOTE: ALL FIXTURES CAN BE SUPPLIED WITH CHEMICAL RESISTANT FINISH.

FIRE EXTINGUISHERS-

The fire extinguishers are all purpose dry chemical powder extinguishers that can be mounted in all the fume hoods when specified. These units give an extra safety factor when dealing with flammable product and help protect the operator and facility. All extinguishers are U.L. approved. We also offer fire suppression systems as well. Dry chemical type for classes A, B, C, & D.



This extinguisher is typically mounted to the fume hoods top located for the best possible fire suppression. Auto melt system is typical or a manual pull system can also be installed. For other special fire suppression needs contact us.
#100-FET-300-F

BLOWER MOUNTING BRACKETS-

There are two variations offered, one is channel cut to size for mounting on top of the fume hood. The second is a stand-alone bracket designed to be mounted on a wall.



WALL MOUNT BLOWER BRACKETS
#100-WMT-BLB-024

SEISMIC WALL MOUNT BRACKETS FOR FUME HOODS (NOT SHOWN)
PART NO. 100-SWM-002

FINISHED BACKS-

For finished backs just take the part number and add the fume hoods width to the last digits in the number. As an example a 48" wide CA hood needs a finished back it would be numbered like:

106-SFB-??? Would actually be numbered as 106-SFB-048

The finished back is typically CRS 18 to 16 gauge powder coated the same finish as the hood unless specified.

The back is secured in place using hardware typically not supplied unless factory installation is required.

ALARMS FOR FUME HOODS:

It is recommended to verify proper fume hood operation and the best way to do this is to use an alarm. Some kind of monitoring device for fume hoods is recommended by OSHA, NFPA 45, and ANSI Z 9.5 standards. Labcase offers alarm systems that have a visual and audio response once the hood falls out of the predetermined settings. This allows the fume hood users to maintain safe face velocities of air flow and maintain a safe laboratory environment. For more information contact Labcase.

Typical alarm used is: TELAFA500 or 1000 or similar models visit TEL at www.TEL.com

Standard features include: Digital display with jumbo colored LED output and audible alarm

- Horn silence
- Field adjustable
- Durable design

Also sash height sensors with audible alarm system can be installed in most units contact your dealer for details.

MANOMETER:

The manometer is designed to monitor pressure differences continuously. The system allows the fume hood user to keep track of pressure loss do to particle build up in the exhausted air filter system. A good example is the use of filter boxes with HEPA filters and pre-filters.

STATIC PRESSURE GAUGE:

The static pressure gauge is a dial type that senses static pressure within a space. Typically mounted in the exhaust duct work and the dial portion is located in the hoods front panel. The system monitors the resistance of airflow (static pressure) through the fume hood. For more information contact Labcase.

FLAMMABLE LIQUID STORAGE CABINETS:

These portable cabinets work well with the ADA compliant hoods. Some of the units depending on type and model come with castors for moving. This mobility is useful when it comes to the ADA hoods it allows the user to roll the cabinet out of the way while using the hood. When you are finished with the fume hood roll the cabinet back for storage. The cabinet is manufactured from furniture steel and painted yellow or a specified color with a large label, "FLAMMABLE". The cabinets are designed to house flammable and combustible materials. The cabinets are welded construction and comply with OSHA and NFPA regulations. There are also standard flammable storage base cabinets for more information contact us. Also see casework section.



24" WIDE BASE FLAME STORAGE



36" ROLL OUT LOW PROFILE
FLAME STORAGE BASE
CASTORS ARE AN OPTION

FLUORESCENT LIGHTS:

The lights are fabricated out of sheet metal with the T-8 ballast mounted internally and is a UL and CSA® approved product which is standard in our fume hoods. To protect the light from exposure a piece of ¼” thick safety glass is used, the glass is adhered to the hood top. The light comes in 2’, 3’, and 4’ lengths depending on size of fume hoods. Wing type brackets are added to the light for placement on lab equipment. The units comply with the federal governments energy efficiency standards. Light bulbs not included.

BULB CHANGING PROCESS
CHANGE FLUORESCENT LIGHTS BY ACCESSING FUME HOODS TOP AREA.

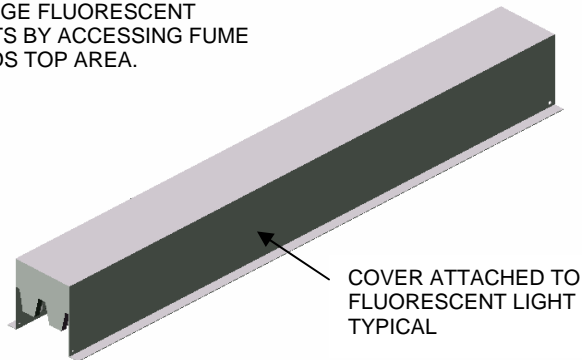

TOP WITH FLOURESCENT LIGHT MOUNTED TO LIGHT SUPPORTS WITH SCREWS AND IS REMOVABLE.

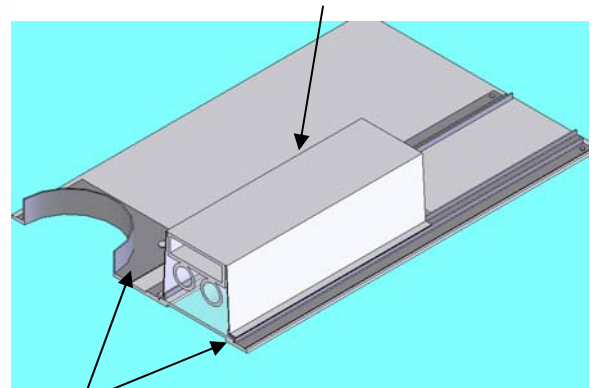

SAFETY GLASS SILICONED TO TOP AS IS THE EXHAUST DUCT

2’ Fluorescent light type T-8 = 118V. 60Hz. AC 85 watts **#10E-FLL-024**
4’ Fluorescent light type T-8 = 118V. 60Hz. AC 160 watts **#10E-FLL-048**

HAZARDOUS CONDITION LIGHTING:

These fixtures are designed to meet the needs of class 1, division 1 locations based on the standards set by the NEC. These units can be used in class 2, and class 3 type locations as well. The light has a corrosion resistant finish and is an aluminum copper free die-cast product housing a prismatic glass globe. The explosion proof light uses a 13-watt fluorescent light that equals or exceeds two 60 watt incandescent lamps at 120V. The unit is a pendant type fixture, when it is mounted on the fume hood a steel channel or bracket is used for securing the unit to the hood top. The light is then sealed to the hood top with silicone. The bulb is accessible through the hoods interior by removing the glass globe. The light fixture is both UL and CSA approved. Light bulbs not included.



Explosion proof light – 120V. with a max bulb size of 600watts
Class 1, Group 1

#505 for Incandescent light model
#506 for Florescent light model

INCANDESCENT VAPOR PROOF LIGHT:

The incandescent light uses a 100-watt bulb that is sealed in a glass globe. The glass globe is removable for replacing the bulb. The fixture is a ceiling type unit with a mounting bracket attached for securing on a fume hood or other device. This device is UL approved. Light bulbs not included. (120V. connection)

ALUMINUM CAST BODY

REMOVABLE GLASS GLOBE

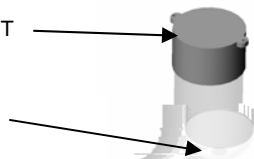

VAPOR PROOF LIGHT
#507

AIR VELOCITY TESTING KITS:

Hand held velocity meters, smoke pots or smoke bottle available for sale upon request.

RECEPTICALS:

There are four variations of duplexes we offer. The 115-volt duplex is the most common but we also offer a 120V. ground fault duplex, 250-volt duplex, and a 250-volt single. All duplexes come with a stainless steel cover plate and mounting hardware. Special outlets are optional.



250V DUPLEX
321FVD

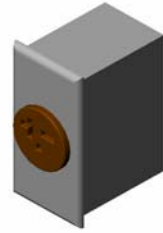

250V SIMPLEX
321FV

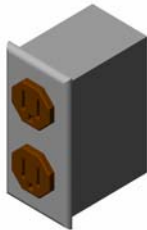

115V DUPLEX
305FVD

120V. GFI
DUPLEX
341FVD-GFI

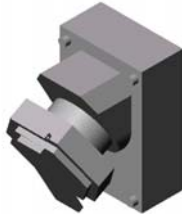

EXPLOSION PROOF OUTLETS
CLASS 1, GROUP 1
325

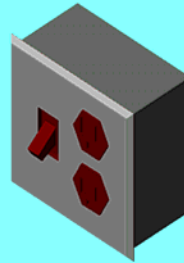

LIGHT SWITCH &
115V.DUPLEX
535FV

SWITCHES:

The light switch is a standard toggle type. The blower switch is also a toggle type switch with a pilot light. All switches come complete with stainless steel cover plates and mounting hardware. We can also supply alternative type switches when requested.



LIGHT SWITCH
SINGLE POLE 15 AMP
W/ STAINLESS COVER
PRT # 400FV



BLOWER SWITCH
MANUAL MOTOR STARTER
W/ PILOT LIGHT
PRT # 411FV

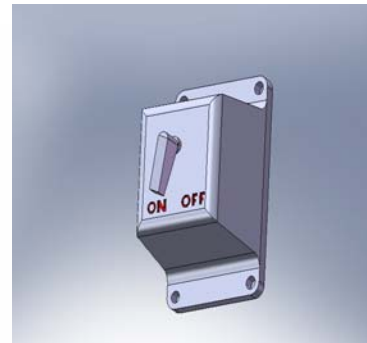

EXPLOSION-PROOF LIGHT SWITCH
OR BLOWER SWITCH BODY
PRT # 530

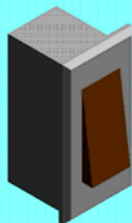

LIGHT SWITCH LARGE
SINGLE POLE 15 AMP W/ COVER PLATE
PLASTIC OR STAINLESS
PRT # 10E-LTS-002



KWICK SWITCH
(TOGGLE)
PRT # 540FV

ACID STORAGE CABINETS:

We offer a complete line of standard base cabinets along with the lined version capable of handling hazardous material storage. More specifically acid storage these units also are ventilated. For more details on ordering cabinets with your fume hoods contact Labcase directly.

35" & 47"
STANDARD
ACID STORAGE W/
TOP
REMOVED



18" & 24" WIDE
LINED CABINET W/ ROOM FOR SINK
ABOVE

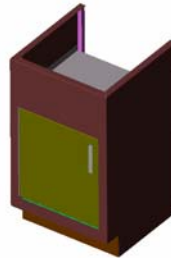

For complete model offerings see casework catalog or data sheets

**SASH OPTIONS:
COMBINATION SASH-**

Combination sash house 1/4" laminated safety glass panels that slide horizontally while the sash they are housed in can slide vertically. The sash operates the same as a standard sash but offers easier access to the hoods interior work space. The hood operator can work within the hood and maintain a safe working environment while maintaining proper face velocities. The sash frame is constructed of furniture steel and painted with a corrosion resistant finish. There are also versions of stainless steel in either 304 and 316 types with a polished finish. The safety glass in all the versions is trimmed out with stainless steel all around. The panels slide in two separate independent channels. To add this feature simply end hood model number with **-HVS**

HORIZONTAL SASH-

This sash allows for easy access into the hood and reduces exhaust air requirements. The horizontal sash allows for the 1/4" laminated safety glass panels to slide left or right depending on number and configuration. The glass panels themselves are trimmed out on all four sides with a stainless steel "c" channel. The panels ride within two channels top and bottom that fit within the sash these components are also stainless steel. The glass panels ride on a ball bearing track within the sash independent of one another. The sash is either constructed of furniture steel with a corrosion resistant finish or stainless steel.

To add this feature to your order add **-HVS** to the end of the hood model. All sash are considered powder coated carbon unless you add **-SS** after the added sash extension so it would look like 100-CAH-048-HVS-SS this part number would be a 48" Control Air hood with Horizontal / Vertical sash all stainless steel.

Plastic glides run in the upper channels

Laminated safety glass panels typical trimmed out in either stainless steel channels or clear plastic.

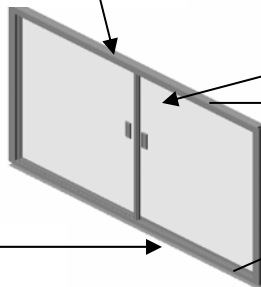

Aluminum track both Top and bottom Channels

Continuous finger lift

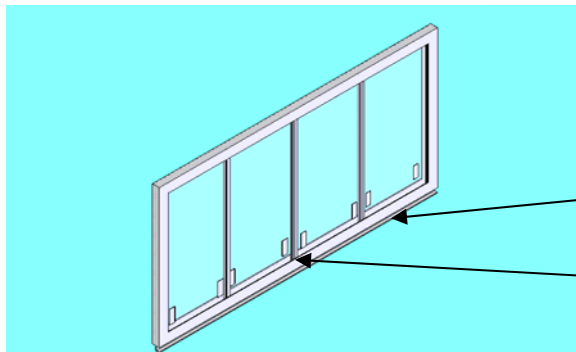

Number of glass panels per sash is as follows unless specified differently:
35" – 60" wide hoods 2 trimmed panels
70" – 96" wide hoods 4 trimmed panels

Plastic wheels in channels are on rails in the bottom channel.

Finger grabs adhesive type

H&V SASH STAINLESS STEEL

Door panel quantities can vary based on customer needs for access into fume hood.

SPLIT SASH ASSEMBLY-

Also note not shown is our post-less sash configurations for hoods 70" and wider when requested. The split sash is connected to two separate counter weights and are independent of each other. The sash share one center attachment beam using an Accuride® type vertical slide device. All other connections and sash frame construction is the same as the standard type sash frame. Manufactured in both steel and stainless steel versions.

PRE-WIRING EQUIPMENT:

Fume hoods can be wired to a junction box on the hoods top typically located at the back. But because of various state and building codes depending on location it is typical to have the specific trade wire the unit on site. This allows the electrical contractor to install the product up to your areas regulations and codes. We also offer just product installation of electrical switches, alarms, and duplexes so when the units arrive on site it is just a matter of running wire and conduit to complete the install. For further details contact your dealer. (Note if shipped outside USA typically not wired)

PRE-PLUMBING:

The fume hoods supplied by Labcase can be plumbed to the units top, back, or below counter top depending on final connection points. We offer a range of piping options from copper pipe to black iron depending on the service. All final connections are made by the proper trades to meet local codes. We also offer just fixture installation with the piping and final connections done on site. As a reference here are the typical materials used for the various services-

Air pipe- copper or black iron

Gas pipe- black iron

Water pipe- copper

Vacuum pipe- copper or black iron

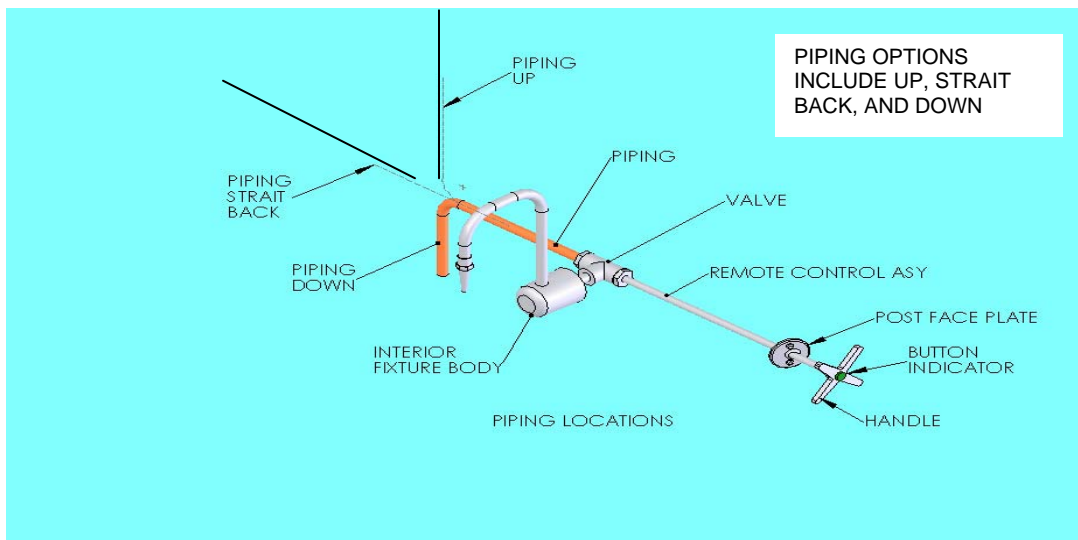
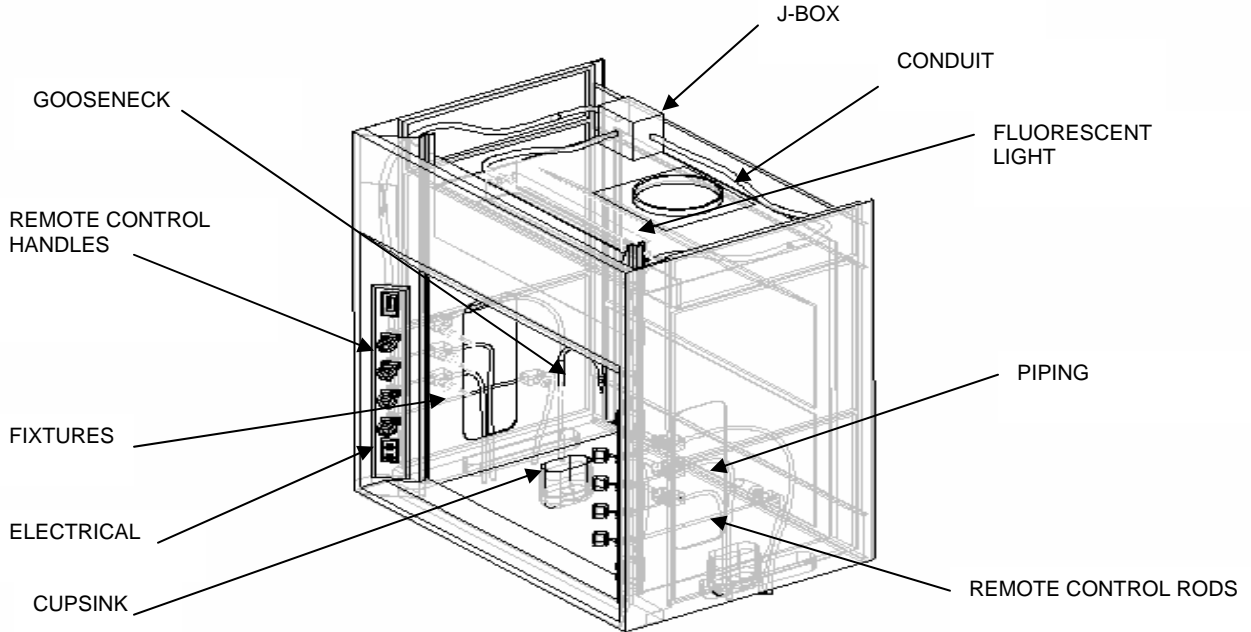

Note: If hoods are shipped outside North America typically they will not be plumbed unless specified. To comply with local codes and specifications the appropriate trades will perform the final install as required at the final destination.

FUME HOOD INTERIOR LINERS:

Poly resin – White fiberglass filled polyester resin material has the same characteristics as the phenolic resin material. **This is a U.L. approved material.**

Phenolic resin – This material has great chemical resistive type properties, it is highly durable and easy to maintain. The product is white and provides a bright atmosphere within the fume hood. This material resists bacteria growth, fungi, and microorganisms cannot penetrate its core. The panels also are moisture resistant and easy to decontaminate. The physical make up of the panels are a nonporous surface that is smooth and has good manufacturability. Uses for this type of material include clinical, microbiological, chemical, and physical areas within laboratories.

Stainless steel - type **#304 stainless steel** will be at least 16 gauge with a number 4 finish. The complete hood interior is fabricated from stainless steel from the baffles to the adjustable baffle including the knobs. The liner can be used in all versions of fume hoods.

PVC – White or gray in color is ¼" thick and is fabricated into parts needed to complete a fume hood interior. This material is a type 1 grade 1 which can withstand highly corrosive environments. The material has a flame spread of less than (25.). This material also cleans easily and maintains a good appearance.

Polypropylene – White polypropylene ¼" thick material is fabricated into the fume hood interior. This includes all the lintel, baffles, side panels, adjustable baffles, back panel, and top. This material has good resistance to acids and solvents. The smooth and bright surface cleans up easily and has good lighting characteristics.

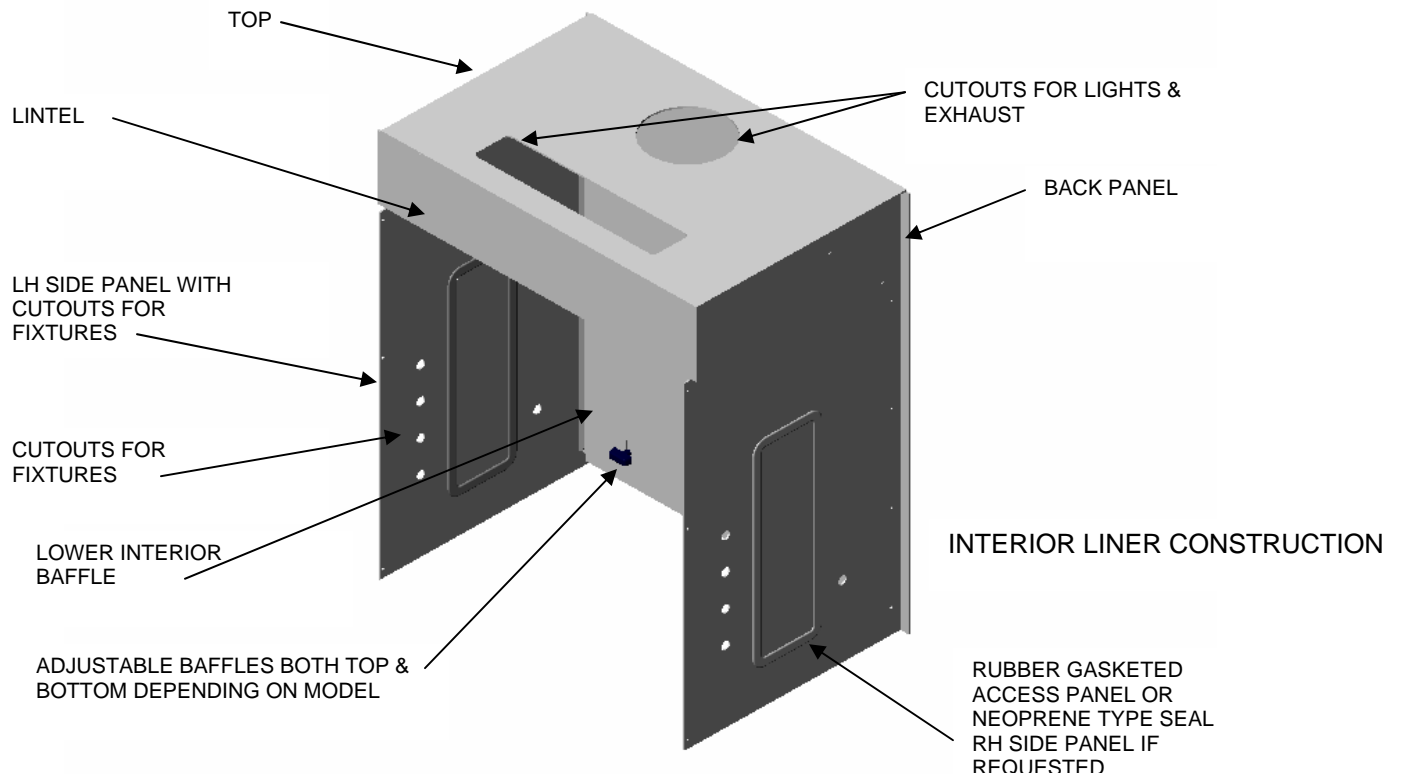

Fume hood liners are typically fastened with stainless steel type hardware.

For more information on liner materials contact your local dealer or representative. We can supply the flame and smoke details along with any MSDS requirements you may have. We do not use asbestos type products in our furniture. If you have a specific need just let us know.

FILLER AND ENCLOSURE PANELS

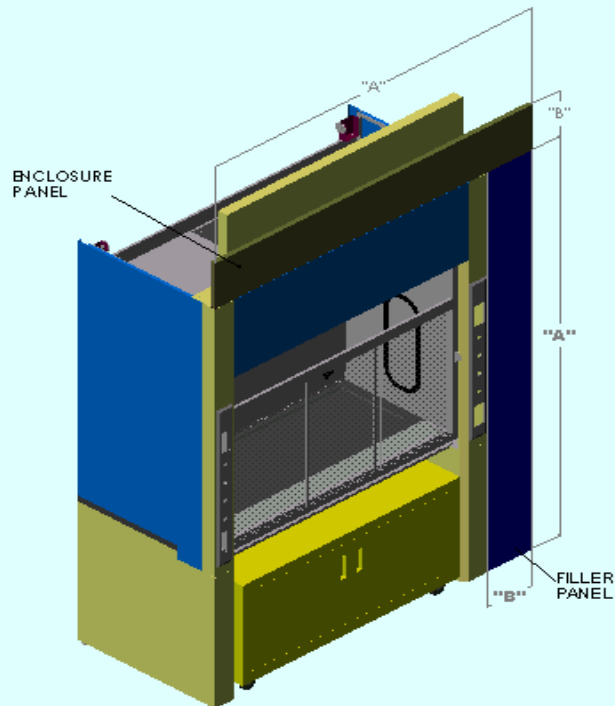

FILLER ASSEMBLIES:

The filler is designed to run vertical with the fume hood to cover any gaps between units or the space at the hoods back running along the wall. The filler is constructed out of furniture steel and painted to match fume hood with a corrosion resistant finish. The fillers length is supplied by the customer typically, for more details contact Labcase.

CEILING ENCLOSURES:

The ceiling enclosures give a fume hood the finish and appearance of a complete floor to ceiling unit. The enclosure occupies the space between the buildings ceiling and the top of the fume hoods structure. This in turn covers up piping, conduit, and the exhaust duct which will also reduce the noise level in the room. The enclosures are fabricated from furniture steel and painted to match the fume hood with a corrosion resistant finish. The height of the ceiling enclosure must be supplied by the customer.

When ordering fillers or enclosures include both the height and the width based on your areas to be closed off. We also offer slip fit enclosures for uneven surfaces. This also helps when the exact distance is not known, the variance allowed is up to 2 1/2".

The fillers can also be used at the wall base cabinet and fume hood juncture. The enclosures can also rap around the hood sides to the wall. We offer enclosure with front or side access for entry into the fume hoods top area for changing light bulbs and general maintenance.

COUNTERTOPS:

The surfaces below are for fume hood work areas along with standard countertop space within the lab.

The countertops can be ordered in various lengths and sizes with added features depending on your needs. Sinks along with fixtures can be supplied with the countertops. The countertops come in two forms epoxy resin which can be dished or flat depending on your needs. The resin countertops are 1 1/4" thick and when there is a dish it is 1/4" deep. The epoxy resin countertops are a special order item with standard sizes and sink cutout locations. The diagram on the next page shows the standard cup sink locations for a 48 CA style hood.

We also offer polished 304 stainless steel counters dished or flat along with the option for sinks and back splashes. The stainless steel tops are constructed of no less than 16 gauge material with internal reinforcing. All areas that are exposed should have a polished finish. The stainless steel countertop is built to your needed lengths and depths. The standard height is 3/4" to 1 1/4" and when there is a dish it is 1/4" deep typically. Also standard sink sizes are ordered as needed based on the customers needs.

Typical cup-sink size will 3" x 6" with a strainer located in the areas described on the next page or placed according to specifications. The sink is fabricated from plastic unless specified to be of another material, color is black. Other sink sizes are available upon request.

See the next page for chart and more ordering information:

COUNTERTOP SIZES FOR FUME HOODS				
STOCK COUNTERTOPS ARE ALL DISHED 1/4" DEEP				
PART NO.	LENGTH	DEPTH	THICKNESS	MATERIAL
905-00S-035	35"	30"	1 1/4"	304 STN. STL.
905-00S-036	36"	30"	1 1/4"	304 STN. STL.
905-00S-047	47"	30"	1 1/4"	304 STN. STL.
905-00S-048	48"	30"	1 1/4"	304 STN. STL.
905-00S-058	58"	30"	1 1/4"	304 STN. STL.
905-00S-060	60"	30"	1 1/4"	304 STN. STL.
905-00S-070	70"	30"	1 1/4"	304 STN. STL.
905-00S-072	72"	30"	1 1/4"	304 STN. STL.
905-00S-094	94"	30"	1 1/4"	304 STN. STL.
905-00S-096	96"	30"	1 1/4"	304 STN. STL.
905-00R-035	35"	30"	1 1/4"	EPOXY RESIN
905-00R-036	36"	30"	1 1/4"	EPOXY RESIN
905-00R-047	47"	30"	1 1/4"	EPOXY RESIN
905-00R-048	48"	30"	1 1/4"	EPOXY RESIN
905-00R-058	58"	30"	1 1/4"	EPOXY RESIN
905-00R-060	60"	30"	1 1/4"	EPOXY RESIN
905-00R-070	70"	30"	1 1/4"	EPOXY RESIN
905-00R-072	72"	30"	1 1/4"	EPOXY RESIN
905-00R-094	94"	30"	1 1/4"	EPOXY RESIN
905-00R-096	96"	30"	1 1/4"	EPOXY RESIN

STAINLESS STEEL –
 Counter tops are fabricated from type 304 stainless steel a minimum of 16 gauge. All edges are ground buffed and polished to a number 4 finish. All tops use hat channels and added support with sound absorbing material for quiet use. Contact your dealer for more details, will quote all shapes and sizes to help fill your requirements.

COUNTERTOPS

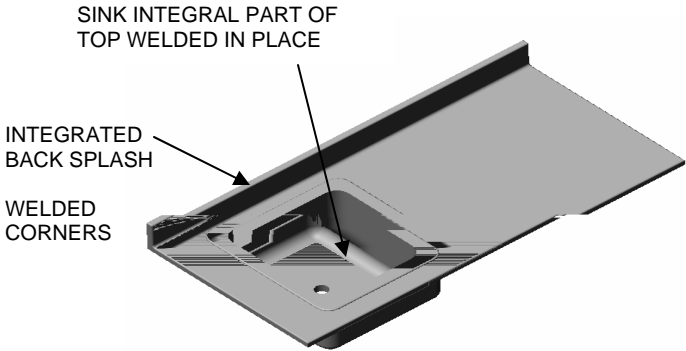

A STAINLESS STEEL COUNTERTOP WITH A SINK AND BACK SPLASH.

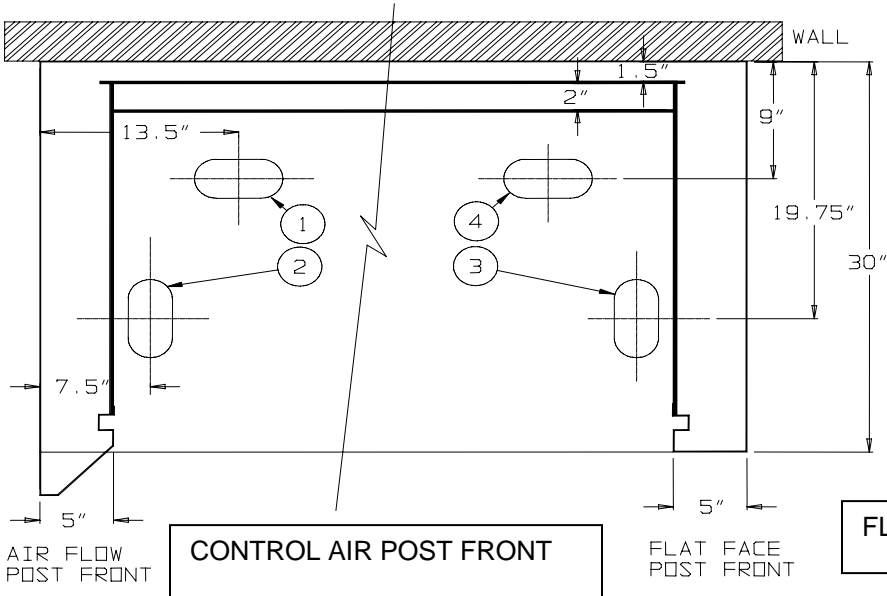
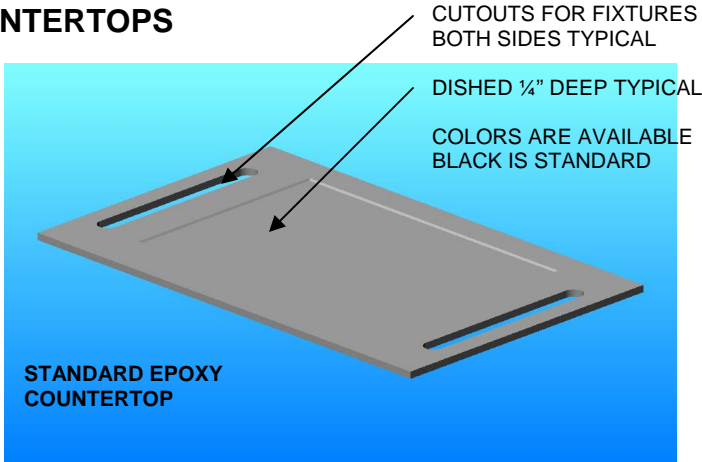

CUPSINK LOCATIONS

- 1. BACK LEFT CORNER
- 2. FRONT LEFT
- 3. FRONT RIGHT
- 4. BACK RIGHT CORNER

DIAGRAM DEPICTING BOTH FLAT FACE AND CONTROL AIR HOOD CUPSINK LOCATIONS.
 (NOTE ALL SLIM WALL HOODS TYPICALLY ARE ORDERED WITH A NON DISHED TOP)

BLOWERS

For blowers we can supply all types and configurations including explosion or spark proof:

For greater details pertaining to blower configurations contact us direct.

Available Blower Features:

- Vibration pads
- Inlet guards
- Vibration rail bases
- Non-overloading belt drive systems
- Pressure blowers
- Direct drive blowers
- Any position discharge
- Auto discharge shutter
- Weather covers
- Belt guard
- Spark resistance types A, B, & C

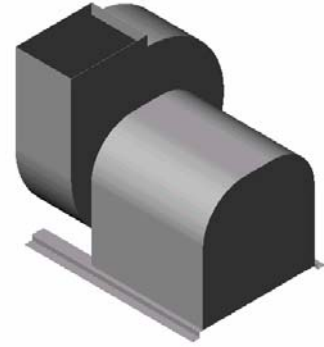

All spark resistant fans conform to:

AMCA Standard 99-0401-86

Typical fan construction is all steel, welded and powder coated for years o

ADD AIR SYSTEMS

Most all fume hoods including the Slim Walled style can utilize the Labcase Add Air System. With the influx of added air the fume hood pulls less from the lab itself and reduces some turbulence in the hoods fascia area. The chamber delivers air through diffusers before being delivered to the fume hoods front. The veined delivery system directs the air in a downward motion to the hoods face where it can be drawn in through the sash opening. If the sash is closed the unit dumps the air into the hood through the top of the sash. The system was designed to reduce turbulence and improve reliability with energy savings in mind.

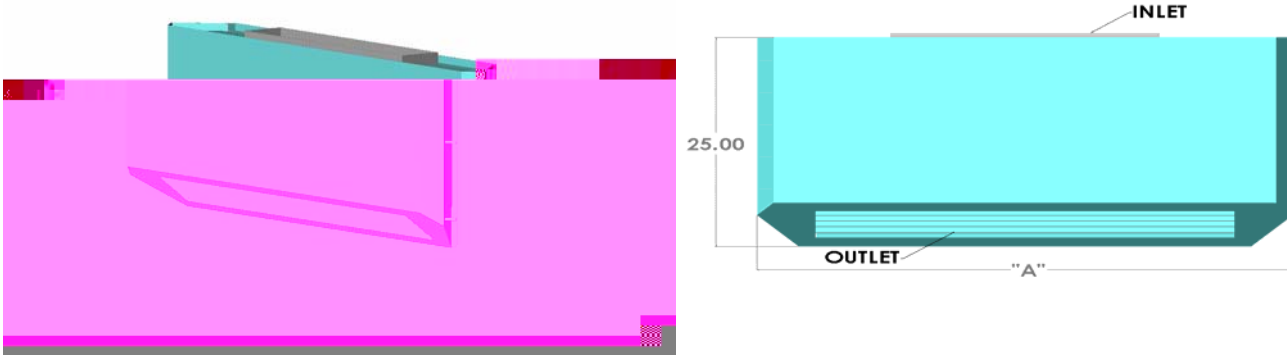

SNORKEL HOODS



Stainless steel snorkel hoods shown.

Hood comes standard with adjustable wall mounting rod assembly to position snorkel.

One ten foot section of 6" diameter flexible duct.

We also offer a plastic version not shown contact your dealer for more information and ordering information.

These local exhaust systems are typically used with atomic absorption spectrophotometers or flame photometer equipment. Also great for local heat / exhaust removal from ovens or burners. Note the plastic version should not be used for heat removal applications.

Stainless steel Snorkel Hood – prt. # 109-012-SNH-SS

Plastic Snorkel Hood – prt. # 109-012-SNH-PL (not shown)

INLINE DUCT FILTER BOXES

This is a dual action cleaning system the box contains a pre-filter and a HEPA filter. The dual stage allows the pre-filter to capture large particulate while the HEPA traps particles as small as 0.3 microns. The box is typically constructed from #304 stainless steel or painted cold rolled steel. The duct openings are 12" diameter inlets and offset outlet of the same size. One bolt on panel allows for access to filters and better seal. **#101-SFB-024** (24" X 24") S.S. Box welded construction. Filter is sealed against neoprene gasket. There are 24", 30", & 36" models.

See top of next page for model:

INLINE FILTER BOX

PREFILTERS AND HEPA FILTER REPLACEABLE

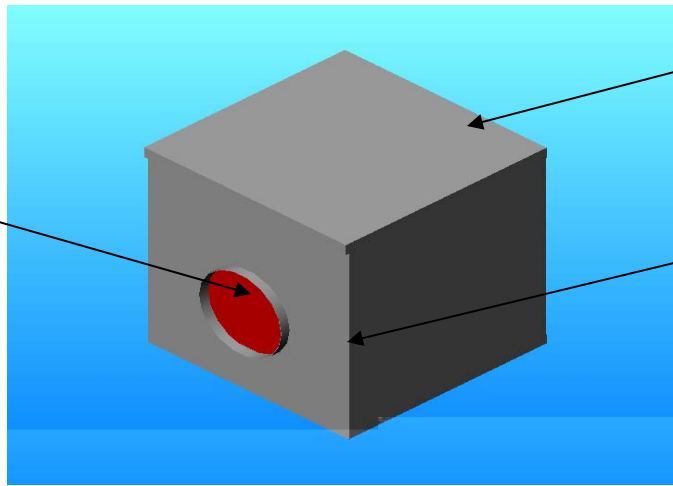

REMOVABLE COVER

WELDED CONSTRUCTION

HEATED WATER BATHS

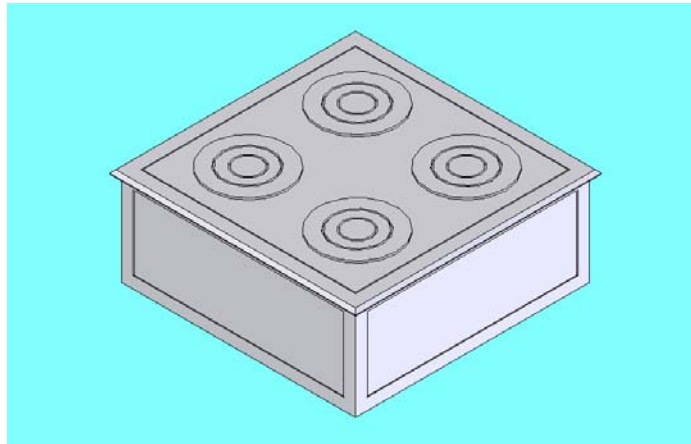

STANDARD PRODUCT FEATURES:

- Stainless steel construction type 304.
- Surface and concentric rings a number 4 finish.
- To retain heat and function properly baths are completely insulated.
- Bath mounts flush with work surface.
- Includes overflow and all elements including controls.

Steam baths come in:
 Steam
 Hot Water
 Electric

F-430
F-431
F-432

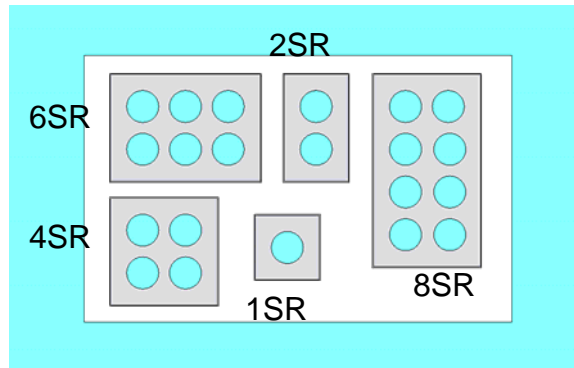

STANDARD SIZES

- 1SR = One set of 6 removable rings
16" X 16"
- 2SR = 2 sets of 5 removable rings
16" X 9"
- 4SR = 4 sets of 5 removable rings
16" X 16"
- 6SR = 6 sets of 5 removable rings
24" X 16"
- 8SR = 8 sets of 5 removable rings
31" X 16"

SASH LOCKS:

Labcase offers a simple cam style sash lock when a specific height has to be maintained, but there are also key locks available when extra security is needed within your lab. For more detailed information on specific locks and their usage contact Labcase directly.

CAM LOCK
 PART NO.
101-CAM-LOC

FIELD MOUNT KIT
 INCLUDES HARDWARE
 AND LOCK
 PART NO.
101-CAM-LOC-F



SPRING LOADED PIN SASH STOP

(Not shown)

Spring loaded device that is hand retractable can either locate itself in the post by adding a hole or add a surface mount bracket and let the plunger hit as a stopping device. This can be field mounted as needed. For kits use the supplied numbers below:

- 1/4" diameter pin use 002-004-SLL-1
- 3/8" diameter pin use 003-004-SLL-2

PRODUCTS OFFERED BUT NOT LISTED:

VENT OR DUCT KITS

LATICE RACKS FOR HOOD INTERIORS

REMOTE ADJUSTABLE BAFFLE FOR FUME HOOD INTERIOR

WOOD OR STAINLESS STEEL EXTERIOR PANELS FOR FUME HOODS

FORENSIC FUMING CABINETS OR CONTROLLED ENVIRONMENTS

GLOVE BOXES

DOWN DRAFT HOODS

HOPEC IV FUME HOODS

BURN BOXES (FOR TESTING FMVSS302 STANDARDS), AND ASTM 162
CONSTRUCTED OF GALVANIZED STEEL WITH A HEAT RESISTANT VIEWING WINDOW.

BURN BOOTHS (BURN EXPERIMENTS / PRODUCT TESTING / FLAMMABILITY) -
A STEEL CONSTRUCTED HOOD WITH A VERTICALLY SLIDING SASH FRAMING A HEAT RESISTANT
VIEWING WINDOW.

DRYING CABINETS AND EVIDENCE LOCKERS

LAMINAR FLOW HOODS

SHELVES INCLUDING STAINLESS STEEL, PHENOLIC, AND CARBON STEEL

GLOSSARY OF FUME HOOD TERMS:

ADA – Americans with Disabilities Act

ADAG – Americans with Disabilities Act Guidelines

Air Foil – Streamlined member at the hood opening designed to improve air flow into the hood

Air Volume – Rate of air flow, expressed in cubic feet per minute (CFM)

ASHRAE – American Society of Heating, Refrigerating and Air Conditioning Engineers, a professional group that sets industry accepted standards for fume hood testing procedures

Auxiliary Air – Supply or make-up air administered externally to the front of the hood to reduce room air consumption

Baffle – Panels located in front of the hoods interior back panel that control the pattern of the air moving through the hood

Bench-Type – Type of fume hood designed to rest atop a pedestal or base cabinets

Blower – Air moving device (fan) consisting of motor, impeller and scroll

Bypass – Compensating opening that allows for unobstructed airflow that helps maintain constant volume exhaust from fume hood, regardless of sash position

Canopy Hood – Ventilating device typically suspended from the ceiling used to dissipate heat, water vapor, odors, etc.

CFM – Cubic Feet per Minute: unit of air volume measurement

Combination Sash – Horizontal sliding safety glass panels in a vertically rising frame, (Sash)

Constant Volume – Type of fume hood exhaust system that exhausts the same volume of air regardless of the sashes position

Containment – Function of fume hood to control fumes within the hoods interior compartment

Damper – A device installed within the duct to control the volume of air passing through

Demonstration Hood – Fume hood accessible from two sides with a viewing window in one end used for demonstration purposes

Duct – Round, square, or rectangular tube used to encapsulate air

Duct Velocity – Speed of air moving through the duct, measured in (FPM)

Exhaust Collar – Place where the exhaust duct connects to the fume hood and passage for all exhausted air from hood

Exhaust Volume – The quantity of air exhausted by the fume hood; the volume of air passing through the duct measured in CFM to maintain a determined face velocity

Face Velocity – Speed of air moving into fume hood through the hoods face opening (sash), measured in (FPM)

FPM – Feet Per Minute; measurement of air velocity

Fume Hood – Five sided ventilated enclosure used in laboratories to control, collect, and exhaust contaminants

Liner – Fume hood interior sides, back, top, lintel, and baffles

Lintel – Portion of fume hood front located above the hoods face opening (sash)

Louvers – Slit-like openings punched into hoods front panels

Magnehelic – Type of gauge suitable for measuring low air pressure

Manometer – Measures air pressure differential

NFPA – National Fire Protection Association

Restricted Bypass Fume Hood – Fume hood operating type, Designed with limited bypass area; commonly used in conjunction with VAV exhaust systems and restricted sash openings

Sash – Sliding safety glass panel set in fume hood face that protects the fume hood operator from exposure to chemicals and fumes inside the hood

Service Fitting - Faucets and gas valves mounted to the fume hood

Static Pressure – Air pressure, or resistance, in the hood or duct, expressed in inches of water

Superstructure – Portion of the fume hood supported by the base cabinets, pedestals, and the work surface or the floor

Total Pressure – The sum of velocity pressure and static pressure as measured in duct

Variable Air Volume – Type of fume hood exhaust system that typically maintains a constant face velocity by adjusting the blower motor speed or the use of a balance damper in response to changes in the sash position

Velocity – speed of air, measured in Feet Per Minute (FPM)

Walk-In – Tall in height type of fume hood, designed for tall and large equipment and apparatus

Water Gauge – Measuring device using the weight of a column of water, calibrated in inches

Work Surface – Top material typically epoxy resin and stainless steel: area in the fume hood where apparatus rests and where work takes place

NIH – National Institute of Health



47CA Hood



48HRH Hood



70CA Hoods

Note:

The information provided within this catalog can change without notification as items maybe modified, dropped, or added.

Distributed by:



Labcase Inc.
PO Box 141261
Grand Rapids, MI 49514

Ph: 616-481-8550
Fax: 616-791-4908
www.labcase.com

Labcase Inc. Products:

Discovery, Discovery LT, Euro, EKO, & Vision Bench Systems, Lynx Ceiling Drop Systems, Fume Hoods and fume / odor removal systems, Tables and student stations, Shelving systems

Copyright 2010 **Labcase Inc.** Contents property of **Labcase Inc.** May not be reproduced without permission. This document does not knowingly contain any untrue materials and products or omission to cause misleading information or guidelines.

LC-08-10
Rev A0